

*Ultrasonic Flow Meters*

# **SONOELIS model series SE 404X and SE 406X**



# *Product application, installation and service manual*

## **Contents**

- 1. APPLICATION**
- 2. FUNCTION**
- 3. DESCRIPTION**
  - 3.1. Basic information**
  - 3.2. Flow meter design**
    - 3.2.1. The split version**
      - 3.2.1.1. Ultrasonic sensor including terminal box**
      - 3.2.1.2. Evaluation electronic unit**
    - 3.2.2. The compact version**
    - 3.2.3. Commercial (invoicing) meters**
- 4. SPECIFICATIONS**
  - 4.1. Ultrasonic sensors: nominal ID, rated and limit flow rates**
  - 4.2. Flow meters: basic technical specifications**
  - 4.3. Sensor selection**
  - 4.4. Communication interface**
- 5. METER INSTALLATION AND APPLICATION; BASIC RULES**
- 6. METER INSTALLATION GUIDE**
  - 6.1. Electronic circuits (the split version)**
  - 6.2. Electrical connections**
  - 6.3. Ultrasonic sensors**
  - 6.4. Mechanical assembly and installation**
- 7. METER COMMISSIONING AND CONTROL**
  - 7.1. The “ECONOMIC” configuration**
  - 7.2. The “STANDARD” configuration**
    - 7.2.1. Display data**
      - 7.2.1.1. Meter status information**
      - 7.2.1.2. Display of measured data**
    - 7.2.2. Review of measured quantities**
    - 7.2.3. Review of the measured quantity units**
    - 7.2.4. Unit conversion table**
  - 7.3. The “COMFORT” configuration**
    - 7.3.1. Data display mode**
      - 7.3.1.1. Volume flow rate**
      - 7.3.1.2. Relative volume flow rate**
      - 7.3.1.3. Mass flow rate**
      - 7.3.1.4. Relative mass flow rate**
      - 7.3.1.5. Volume**
      - 7.3.1.6. Volume +**
      - 7.3.1.7. Volume –**

# *Product application, installation and service manual*

- 7.3.1.8. Mass
- 7.3.1.9. Mass +
- 7.3.1.10. Mass –
- 7.3.1.11. Temperature
- 7.3.1.12. Density
- 7.3.1.13. Sound propagation velocity
- 7.3.1.14. Fluid flow velocity
- 7.3.1.15. Start of the measurement period
- 7.3.1.16. Duration of the measurement period
- 7.3.1.17. Duration of failure period
- 7.3.1.18. Power failure period
- 7.3.1.19. Date
- 7.3.1.20. Time
- 7.3.2. Parameter setting mode
  - 7.3.2.1. Password
  - 7.3.2.2. Meter setting procedure
  - 7.3.2.3. Language selection
  - 7.3.2.4. Measuring unit selection
  - 7.3.2.5. New password definition
  - 7.3.2.6. Initial quantity selection
  - 7.3.2.7. Definition of limit values
  - 7.3.2.8. Resetting aggregate quantities
  - 7.3.2.9. Meter zero setting
  - 7.3.2.10. End of parameter setting
- 7.4 Automated meter test
  
- 8. SERVICE ACTIVITIES
  - 8.1. Warranty services
  - 8.2. Post-warranty services
  
- 9. STANDARD TESTS
  
- 10. VERIFICATION TESTS
  
- 11. PACKAGING
  
- 12. PRODUCT ACCEPTANCE PROCEDURE
  
- 13. WARRANTY CONDITIONS
  
- 14. PRODUCT ORDERING

# Product application, installation and service manual

## 1. APPLICATION

Ultrasonic flow meters SONOELIS - models SE 404X and SE 406X can be used to measure instantaneous flow rate, mass flow rate as well as the aggregate quantity or mass of fluid passing through the meter sensor over a given period of time. The measurement method used allows application of the SONOELIS flow meters for a wide range of fluid types including non-conductive and specific corrosive fluids. Therefore the flow meters can be used to measure flow rates of water and other technological fluids, e.g. in chemical plants. The meters are equipped with the necessary HW and SW facilitating communication with superordinated control systems.

The flow meter may include either a single-ray (UC 3.0) or a double-ray (UC 5.0) sensor. The type designations of various meter configurations and their components are given in a table in section 3.1 below.

## 2. FUNCTION

The SONOELIS flow meter utilises the impulse-wave transit-time method where the fluid flow velocity is determined from the flight time of the ultrasonic signal between two ultrasonic transducers. The flight times are measured for both directions of the signal wave propagation (upstream and downstream) whereby any asymmetry in the transducer positions are effectively eliminated.

The flight time of an ultrasonic wave travelling downstream the fluid flow can be determined as follows:

$$t_1 = \frac{l}{c + v \cdot \cos \alpha} + \frac{l_1}{c_1} \quad [s]$$

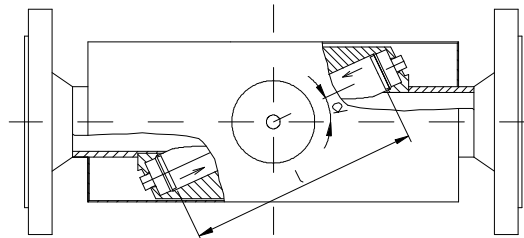

- where  $l$  is the distance between the head parts of the ultrasonic transducers [m]  
 $c$  is the ultrasonic signal propagation velocity [m/s] in the flowing fluid  
 $v$  is the fluid flow velocity [m/s]  
 $l_1$  is the aggregate thickness of the bottom parts of the transducers [m]  
 $c_1$  is the ultrasonic signal propagation velocity [m/s] in the transducer body material.

The flight time of an ultrasonic wave travelling upstream/downstream the fluid flow is defined by the following formula; the difference between the “downstream” ( $t_1$ ) and “upstream” ( $t_2$ ) flight times is given by the different signs of the fluid flow velocity term in the fraction denominator.

$$t_2 = \frac{l}{c - v \cdot \cos \alpha} + \frac{l_1}{c_1} \quad [s]$$

For a given transducer,  $l_1$  and  $c_1$  are known constants.

The ultrasonic signal propagation velocity can be expressed as:

- $v_1 = c + v \cdot \cos \alpha$  for the case of downstream measurement, and  
 $v_2 = c - v \cdot \cos \alpha$  for the case of upstream measurement.

# *Product application, installation and service manual*

Therefore, the difference between the velocities of ultrasonic signals travelling downstream and upstream is proportional to the fluid flow velocity  $v$  [m/s].

$$v = \frac{v_1 - v_2}{2 \cdot \cos \alpha}$$

The instantaneous fluid flow rate  $q$  is defined by the following formula:

$$q = v \cdot s \cdot k(v) \quad [m^3 / s]$$

where  $v$  is the fluid velocity [m/s]

$s$  is the effective cross-section of the flow meter sensor [m<sup>2</sup>], and

$k(v)$  is a correction coefficient the magnitude of which depends on the fluid velocity.

This coefficient reflects the varying fluid velocity profile in the hydraulic section of the flow meter.

## **3. DESCRIPTION**

### **3.1. Basic information**

Ultrasonic flow meters SONOELIS SE 404X and SE 406X are electronic devices designed for measurement of fluid flow parameters in a piping completely filled with the flowing fluid. The meter consists of a fluid flow sensor (UC 3.0 or UC 5.0) and an evaluation electronic unit. These two parts can either be separated or designed as a compact unit. While UC 3.0 includes two ultrasonic transducers (a single-ray sensor), UC 5.0 is a double-ray sensor including four transducers. Sensor UC 5.0 provides for better coverage of the fluid velocity profile under a wide range of operational conditions, in particular with low fluid flow velocities where various irregularities in the velocity profile may occur. The application of this sensor extends the range of measured values, allows for shorter fluid-flow stabilisation piping sections at the meter input and output and generally increases the measurement accuracy.

In the case of a split version of the meter (with separate sensor and the associated electronic unit), the sensor is connected to the electronic unit by two (or four) co-axial cables of adequate length. Both “compact” and “split” versions of the meter are available in the following configurations:

<b>ECONOMIC</b>	a basic version of a fluid flow-rate meter providing for conversion of the measured physical quantities to electric signals.
<b>STANDARD</b>	as the ECONOMIC model, plus an LC display with optional readings of the instantaneous flow-rate or of the aggregate fluid-volume values. If made complete with a Pt 100 temperature sensor, the fluid temperature and fluid mass measurements and readings may be obtained.
<b>COMFORT</b>	as the STANDARD model, plus a panel with four push-buttons facilitating access to the user meter-control menu and functions.

# Product application, installation and service manual

Type and model designations of flow meters and their components

System configuration	Designation				Evaluation electronic unit configuration
	Meter model	Evaluation electronic unit (compact version)	Evaluation electronic unit (split version)	Flow sensor	
ECONOMIC	SE 4040	UP 2.00	-	UC 3.0	Basic
	SE 4041	-	UP 2.10		
	SE 4060	UP 2.00	-	UC 5.0	
	SE 4061	-	UP 2.10		
STANDARD	SE 4042	UP 4.00	-	UC 3.0	Basic + LC display
	SE 4043	-	UP 4.10		
	SE 4062	UP 4.00	-	UC 5.0	
	SE 4063	-	UP 4.10		
COMFORT	SE 4044	UP 3.00	-	UC 3.0	Basic + LC display + push-button control panel
	SE 4045	-	UP 3.10		
	SE 4064	UP 3.00	-	UC 5.0	
	SE 4065	-	UP 3.10		

Regarding function, the evaluation electronic unit of the flow meter can be divided into the following sections:

- sensor isolation circuits
- sensor output switches
- ultrasonic transducer
- ultrasonic receiver including sensitivity control circuits
- interface circuits to the signal evaluation processor
- signal evaluation processor
- circuits for isolated current, frequency and impulse outputs
- serial communication line circuits
- power supply circuits.

The basic configuration of the evaluation electronic unit includes frequency and impulse outputs. All output signals are isolated from the rest of the meter circuits.

Optional electronic accessories can further enhance the meter functions. Among these are: RS 485 communication interface, isolated current output and resistance thermometer Pt 100. The thermometer measures the temperature of the flowing fluid and its readings can be used to convert the fluid rate and volume data into the mass flow data. In the "split" version, the basic range of the permitted fluid temperatures can be extended to  $-20 / +180^{\circ}\text{C}$ . The meter can measure the fluid flow parameters in both directions with indication of the flow direction.

The electronic unit in the standard configuration includes a logic output switch whose function and parameters can be set through the system software according to the customer's requirements, selecting one of the following functions (in the COMFORT meter version, each of these functions with the exception of the first one on the list can be conveniently selected using the push-button panel, see section 7.3.2.7 below):

- indication of the fluid flow direction
- indication of measured values exceeding the preset level of volume flow rate
- indication of measured values exceeding the preset level of mass flow rate
- indication of measured values exceeding the preset aggregate fluid volume level
- indication of measured values exceeding the preset aggregate fluid mass level
- indication of measured values exceeding the preset temperature level
- meter failure indication.

# Product application, installation and service manual

The active state of the switching output can be selected either closed or open.

An adaptive filter included in the signal processing circuits suppresses short-term fluctuations of the measured flow-rate values due to pulsation of the fluid in the piping, flow disturbances following action of the flow control devices or other external interferences. In the standard meter configuration, the filter causes the signal output and the displayed flow values to be delayed by several seconds with respect to the real-time fluid flow status.

However, should a particular application require a very fast response of the flow meter, the signal-processing system can be modified to ensure that the measured data reflect real-time instantaneous parameters of the fluid flow. Minimum delays in the flow data measurement and processing are usually necessary in fluid-dosing systems and similar technological applications.

## 3.2. Flow meter design

### 3.2.1. The split version

#### 3.2.1.1. Ultrasonic sensor including terminal box

On the outside, the two sensor models (UC 3.0 and UC 5.0) look the same. The principle difference consists in the number and arrangement of the incorporated ultrasonic transducers. Sensor UC 3.0 includes two ultrasonic transducers, sensor UC 5.0 four transducers.

The sensor body is a stainless-steel welded structure consisting of inner pipe with welded-on ultrasonic transducer holders. The flanges (made of construction or stainless steel, according to the customer requirements) are welded to the ends of the inner pipe. The transducers are provided with hermetic covers made of construction or stainless steel. The electric terminal board is accommodated in an aluminium box with a thermal insulation insert between it and the sensor body. The electrical connections are led through two (in the case of a single-ray sensor) or four (double-ray sensor) PG 9 coaxial leadthroughs. A special valve prevents water condensation inside the terminal box. The surface finish of the sensor assembly is a powder-paint coating, hue RAL 7035 for the sensor body, and RAL 7016 for the terminal box. The sensor assembly dimensions are shown in the following table:

Dimensional sketch of the sensor assembly

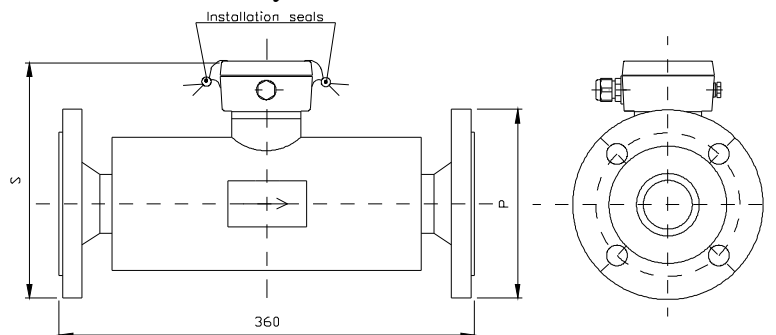

PN	Nominal dim.	DN 32	DN 40	DN 50	DN 65	DN 80	
16/40	Ø P [mm]	140	150	165	185	200	
16/40	S [mm]	181	191	206	220	237	
16/40	L [mm]	360	360	360	360	360	
PN	Nominal dim.	DN 100	DN 125	DN 150	DN 200	DN 250	DN 300
16	Ø P [mm]	220	250	285	340	405	460
16	S [mm]	256	285	314	361	419	471
40	Ø P [mm]	235	270	300	375	450	515
40	S [mm]	263	296	321	379	441	499
16/40	L [mm]	360	360	360	450	450	450

# Product application, installation and service manual

Weight of the UC 3.0 ultrasonic sensors [kg]		
DN	PN 16	PN 40
32	9	9
40	9	9
50	11	11
65	12	12
80	15	15
100	17	17
125	18	20
150	19	21
200	28	37
250	45	70
300	58	84

Weight of the UC 5.0 ultrasonic sensors [kg]		
DN	PN 16	PN 40
32	12	12
40	16	16
50 ÷ 300	the same as UC 3.0	

## 3.2.1.2. Evaluation electronic unit

The evaluation electronic unit of the flow meter is located in a plastic box with a metal sheet base to be mounted on a vertical support plate. At the front panel of the box there are the flow meter trade name and model/type designation, product series number, the manufacturer's trade name and logo, illuminated two-line display (configurations STANDARD and COMFORT) and a control panel including four membrane push-buttons (COMFORT only). A terminal strip is located at the bottom part of the box. To access the terminals it is necessary to remove a plastic cover under seals. Fitted at the bottom wall of the box there are an earthing bolt and at least five plastic leadthroughs (one PG 9 and four PG 7) for cables of circular cross-section. A leadthrough size PG 9 will accommodate (and provide for air-tight assembly of) a cable of external diameter 6 to 8 mm, a PG 7 for a cable of external diameter 4 to 6 mm. Instead of one PG 7 leadthrough, a four-pole connector for the RS 485 line can be fitted.

Dimensional sketch of the electronic unit (the COMFORT configuration)

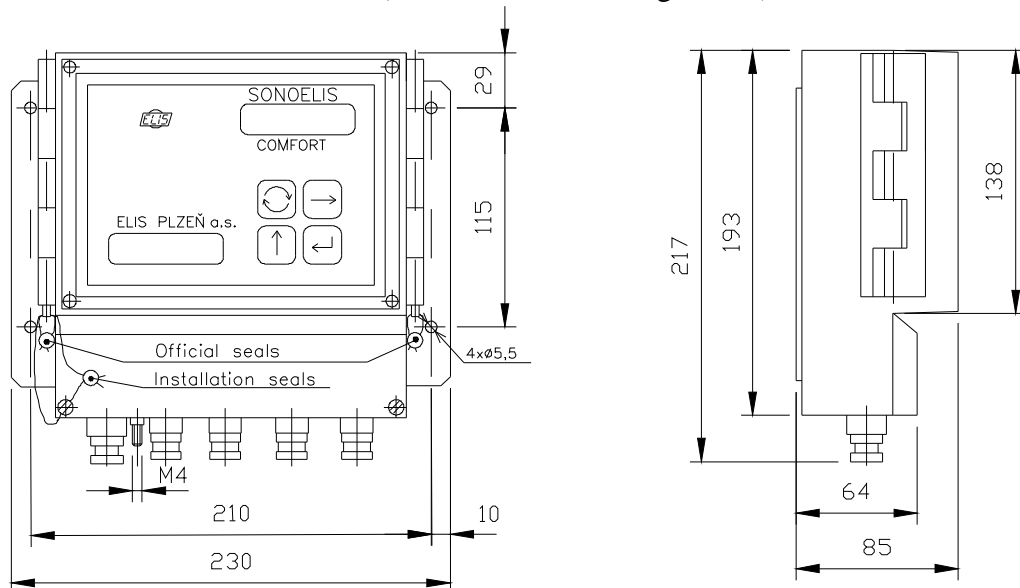

# Product application, installation and service manual

## 3.2.2. The compact version

In the compact version, the evaluation electronic unit is mounted directly onto the meter sensor (UC 3.0 or UC 5.0, see section 3.2.1.1 above) instead of the sensor terminal box. The electronic circuits are fitted into a cast aluminium box coated with an RAL 1017 paint. As with the terminal box in the split version, a thermal insulating insert is placed between the aluminium box and the sensor body. The mechanical connection is provided by four bolts M5 with hexagon socket heads. With the bolts loosened the box can be rotated in horizontal plane by 340°. At the rear part of the box there is a terminal strip under a cover held in position by six bolts M4 with hexagon socket heads. The bottom wall of the box incorporates five leadthroughs (one PG 9 and four PG 7) for cables of circular cross-section and a special valve preventing water condensation inside the box. The leadthroughs can accommodate and provide for airtight connection of cables of diameter 6 to 8 mm (PG 9) or 4 to 6 mm (PG 7). The electronic unit is delivered with blinded bushings. At the front panel, there is the flow meter specification information (meter name and model designation, as well as the manufacturer's trade name). In the case of the STANDARD configuration, there is also an illuminated two-line display; while the COMFORT model further includes a display and a control push-button panel. Before starting-up check if all used bushings are tight properly and all unused bushings blinded in appropriate way.

Dimensional sketch of a compact version of the flow meter

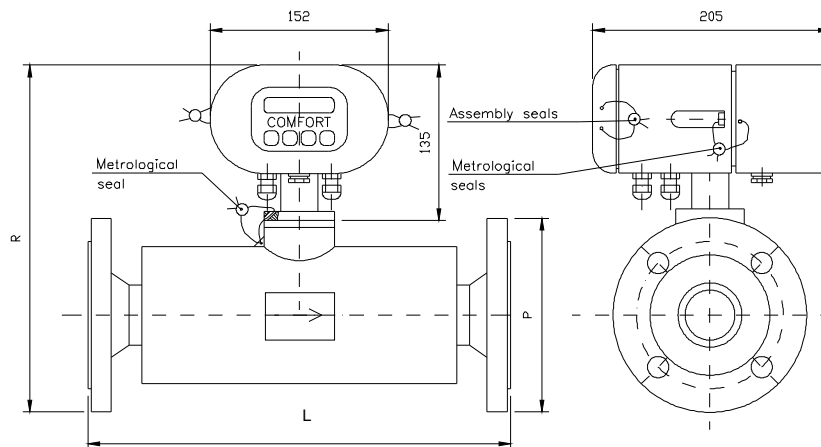

PN	Nominal dim.	DN 32	DN 40	DN 50	DN 65	DN 80
16/40	∅ P [mm]	140	150	165	185	200
16/40	R [mm]	268	278	293	307	324
16/40	L [mm]	360	360	360	360	360

PN	Nominal dim.	DN 100	DN 125	DN 150	DN 200	DN 250	DN 300
16	∅ P [mm]	220	250	285	340	405	460
16	R [mm]	343	372	401	448	506	558
40	∅ P [mm]	235	270	300	375	450	515
40	R [mm]	350	383	408	466	528	586
16/40	L [mm]	360	360	360	450	450	450

## 3.2.3. Commercial (invoicing) meters

Calibrated meters used for commercial purposes need be provided with officially certified seals to ensure that no unauthorised modification of the meter functions or readings may take place. The official certification and meter protection consist of:

- Stick-on labels with official seals of the responsible organisation to be attached on top of the meter type plate on the evaluation electronic unit box;
- Two (or three, in the case of a compact version of the meter) official seals on the covers of the electronic unit box to prevent any unauthorised meter setting action.

# Product application, installation and service manual

Further protective measures shall be adopted after the meter has been installed by a duly authorised technical organisation:

- Two installation seals with official symbols imprinted thereon to prevent unauthorised opening of the cover of the sensor terminal box (in the case of a split version of the meter);
- One (or two, in the case of a split version of the meter) installation seals with official symbols imprinted thereon to prevent unauthorised opening of the terminal cover on the evaluation electronic unit box.

## 4. SPECIFICATIONS

### 4.1. Ultrasonic sensors: nominal ID, rated and limit flow rates

For a given size of the flow meter sensor (UC 3.0 or UC 5.0), the maximum flow rate and other sensor parameters can be found in the following table.

The data in the table relate to the measurement accuracy of flow rate  $q$  better than  $\pm x\%$  and the measurement range of  $q_{\min x\%} \leq q \leq q_s$

Flow meter model SE 404X

DN	32	40	50	65	80	100	125	150	200	250	300
$q_s$ [m <sup>3</sup> /h]	20	32	50	80	150	240	350	500	900	1400	2000
$q_p$ [m <sup>3</sup> /h]	10	16	25	40	75	120	175	250	450	700	1000
$q_{\min 1\%}$ [m <sup>3</sup> /h]	1.5	2.3	3.5	6	9	14	22	32	57	89	127
$q_{\min 5\%}$ [m <sup>3</sup> /h]	0.2	0.32	0.5	0.8	1.5	2.4	3.5	5.0	9.0	14	20
$q_{NEC}$ [m <sup>3</sup> /h]	0.07	0.09	0.14	0.22	0.37	0.6	0.9	1.2	2.2	3.5	5

Flow meter model SE 406X

DN	32	40	50	65	80	100	125	150	200	250	300
$q_s$ [m <sup>3</sup> /h]	20	32	50	80	150	240	350	500	900	1400	2000
$q_p$ [m <sup>3</sup> /h]	10	16	25	40	75	120	175	250	450	700	1000
$q_{\min 0,5\%}$ [m <sup>3</sup> /h]	1.5	2.3	3.5	6	9	14	22	32	57	89	127
$q_{\min 3\%}$ [m <sup>3</sup> /h]	0.2	0.32	0.5	0.8	1.5	2.4	3.5	5.0	9.0	14	20
$q_{NEC}$ [m <sup>3</sup> /h]	0.07	0.09	0.14	0.22	0.37	0.6	0.9	1.2	2.2	3.5	5

where

- $q_s$  is the overload (maximum) fluid flow rate,
- $q_p$  is the steady-state (rated) fluid flow rate,
- $q_{\min}$  is the minimum flow rate for specified measurement accuracy, and
- $q_{NEC}$  is the sensitivity threshold (flow rate) level of the sensor concerned.

The minimum flow rate at which the flow meter starts to measure and deliver measured data is set by the manufacturer at the value of  $q_{NEC}$ . On customer's request this threshold level can be reset within the range of  $q_{NEC} = 0 \div 0,25q_s$ . In the COMFORT meter configuration, the setting of the threshold level can be changed in service using the appropriate procedure for the meter parameter adjustment.

# Product application, installation and service manual

## 4.2. Flow meters: basic technical specifications

Rated pressure of the measured fluid (PN)	40 or 16
Temperature of the measured fluid	0 to +150 °C (split version) 0 to +90 °C (compact version)
Ambient temperature	+5 to +55 °C
Maximum ambient relative humidity	80 %
Storage temperature	-10 to +70 °C at the relative humidity up to 70 %
Protection class	
- evaluation electronic unit, compact version	IP 67
- evaluation electronic unit, split version	IP 65
- ultrasonic sensors UC 3.0, UC 5.0	IP 67
Sensor installed in piping	Flanges 11, ČSN EN 1092-1
Connecting cables for sensors	Standard length 5 m, maximum length 100 m
Max. difference in cable lengths	0.1 m
Electronic unit, split version	
- dimensions	length 230 mm, height 217 mm, width 85 mm
- weight	1.5 kg
- power supply	90 ÷ 260 VAC, 50/60 Hz 24 V AC/DC ±10 %
- stand-by power supply	3 V, Li battery (Lifetime 5 years)
- power requirement	6 VA
- mains fuse	T 250 mA, 250 V; T 1A, 250 V (power supply 24 V DC)
- protection against electric shock, ČSN 332000-4-41	automated disconnection from power supply in the TN-S network
Evaluation electronic unit, compact version	
- dimensions	length 152 mm, height 135 mm, width 205 mm
- weight	2.5 kg
- power supply	90 ÷ 260 V AC, 50/60 Hz 24 V AC/DC ±10 %
- stand-by power supply	3 V, Li battery (Lifetime 5 years)
- power requirement	6 VA
- mains fuse	T 250 mA, 250 V; T 1A, 250 V (power supply 24 V DC)
- protection against electric shock, ČSN 332000-4-41	automated disconnection from power supply in the TN-S network
Fluid flow velocity	minimum 0.1 m/s
	maximum 10 m/s
Display (configurations STANDARD and COMFORT)	2 x 16-digit alphanumerical LC display
Outputs (optoelectronically isolated)	impulse, 0.1 to 1,000 l/imp (impulse length 50 ms)
	frequency, 0 to 1,000 Hz or 10 kHz (corresponds to flow rate 0 to $q_s$ )
	switching output 24 V AC/0,1 A

# Product application, installation and service manual

Optional equipment	communication line RS 485
	isolated current output 0 ÷ 20 mA or 4 ÷ 20 mA (corresponding to the flow rate range of 0 to $q_s$ )
	mass flow rate measurement accessory
	modification for extended range of fluid temperature measurements; from - 20°C to +180°C (split version)
	pipe-end flanges, flange packing pieces, bolts and nuts
	sensor's protection IP 68
	two direction flow measurement and direction indication

## 4.3. Sensor selection

The meter sensor shall be selected with respect to the fluid flow parameters at the measuring location. The normal steady-state flow rate should be as close as possible to the  $q_p$  value (the rated flow rate) of the sensor (see the table in section 4.1 above). Attention shall be also paid to the pressure loss value of the sensor which, although it is generally very low, adds up to the total losses of the fluid piping, in particular at high flow velocities. In applications where the standard sensor parameters do not meet the operational requirements, the values of  $q_s$  and  $q_{min}$  of the selected sensor size can be re-set (in the COMFORT configuration using the customer control push-button panel). The graph below shows the pressure loss values at various flow rates for particular sensor sizes. It holds that the sensor parameter  $q_{min}$  is a fixed value in respect of the given measurement accuracy and the sensor parameter  $q_s$  should not, for the given sensor size, exceed the maximum value given in the table in section 4.1.

### Pressure losses of ultrasonic sensors

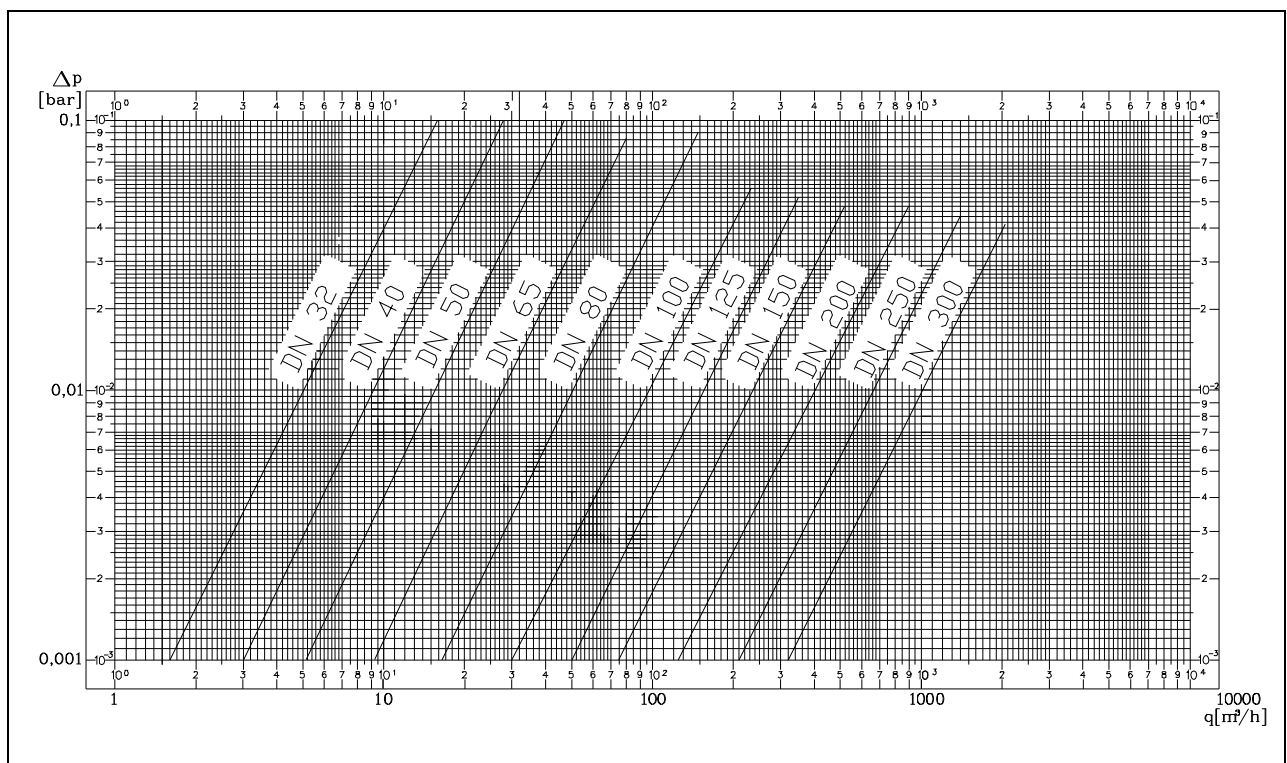

# Product application, installation and service manual

## 4.4. Communication interface

All SONOELIS ultrasonic flow meters can be provided with isolated serial communication line RS 485. The communication line parameters are: baud rate 4,800 Bd, 8-bit data format, one non-data bit, and optional parity in both signal transmission directions. The communication protocol includes, among others, the measured and processed fluid flow data such as instantaneous volume or mass flow rates, the total volume or mass of the fluid flow, and the lengths of the periods of the meter operation, meter failure and power supply failure.

## 5. METER INSTALLATION AND APPLICATION; BASIC RULES

The ultrasonic flow meter shall be applied/installed in observance of certain rules concerning meter placement in the fluid piping so as to ensure that the measurement accuracy complies with the meter specifications. Thus sensor UC 3.0 requires flow-stabilisation straight sections of piping of the length of 5D (D = sensor ID) at the input and 3D at the output where such arrangement effectively eliminates any flow disturbances due to 90° pipe bends, changes in the piping diameter or similar simple flow-interference factors. With sensor UC 5.0, the same flow stabilisation arrangement ensures a wider range of measured values at the specified measurement accuracy (see section 4.1).

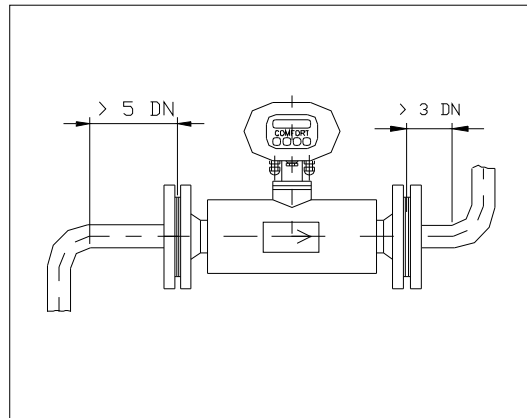

Required straight piping sections to stabilise the fluid flow through the sensor

If there is a pump located in the piping on the input side of the flow sensor, the required length of the stabilisation piping is 20 D. If there is a valve or similar flow control element at the sensor input, the required stabilisation length is 40 D. If such control element is fully open, the stabilisation length is 10 D.

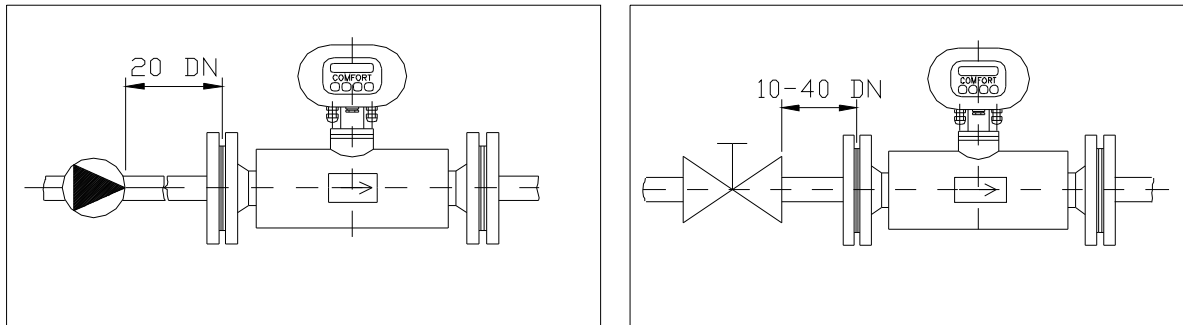

Straight piping sections to stabilise the fluid flow after a "disturbance" in the piping

If any fluid-flow control element is located in the piping on the sensor output side, the sufficient length of the flow stabilisation piping is 3 D.

# Product application, installation and service manual

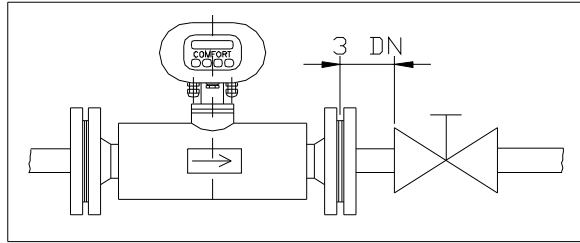

Required straight piping section for a “disturbance” located at the sensor output

In the cases where, in the periods of low flow rate, the fluid level in various parts of the piping may sink, the flow meter sensor shall be located at a bottom pocket of the piping to ensure full flooding of the sensor at all times.

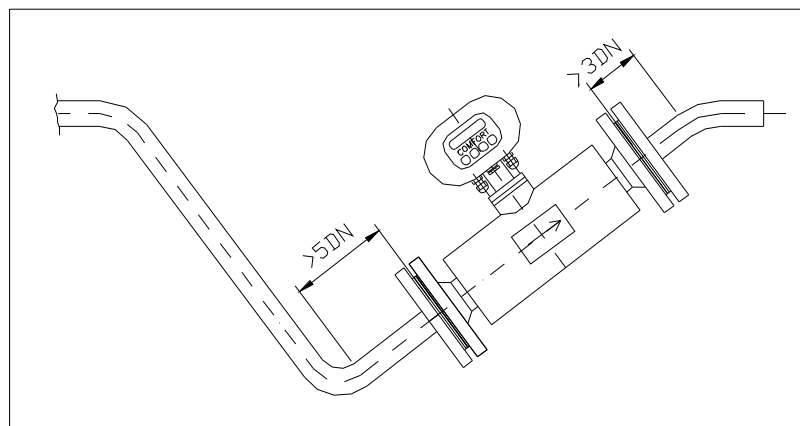

Flow sensor location at the “bottom pocket” of the fluid piping

If a flow sensor is to be installed in a vertical section of the fluid piping, the fluid flow direction shall always be upwards.

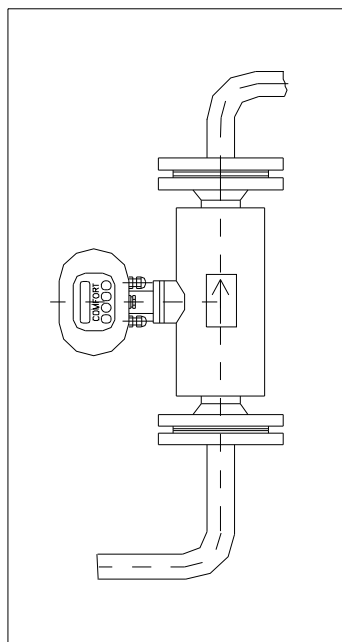

Sensor installed in a vertical section of the fluid piping

# *Product application, installation and service manual*

To ensure correct flow rate measurement, the internal section of the meter sensor shall always be filled with the flowing fluid. Therefore the basic rule to follow regarding the meter sensor placement is to avoid top pockets in the fluid piping and, in the cases where the sensor is located in a vertical section of the piping and/or near the place where the fluid leaves the piping system, the flow direction in the sensor should not be downwards.

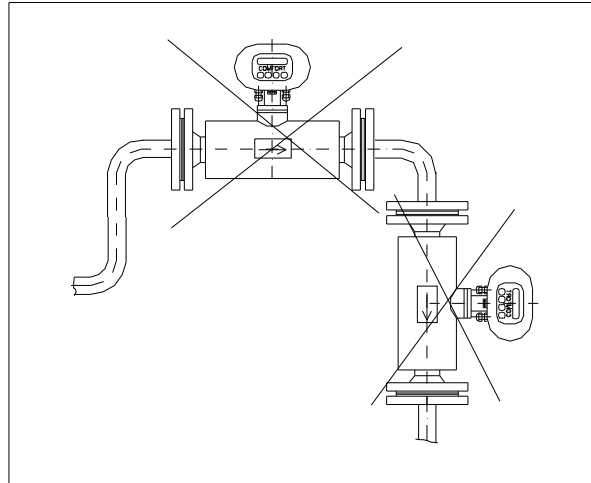

Examples of incorrect sensor placement

The following pictures show correct and incorrect ways of the sensor installation in a horizontal piping section with respect to the possible positioning of the meter display unit.

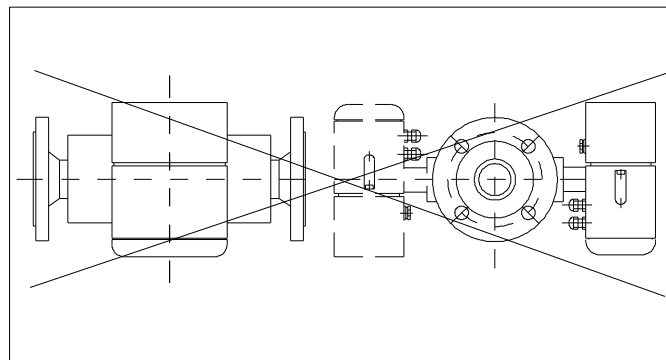
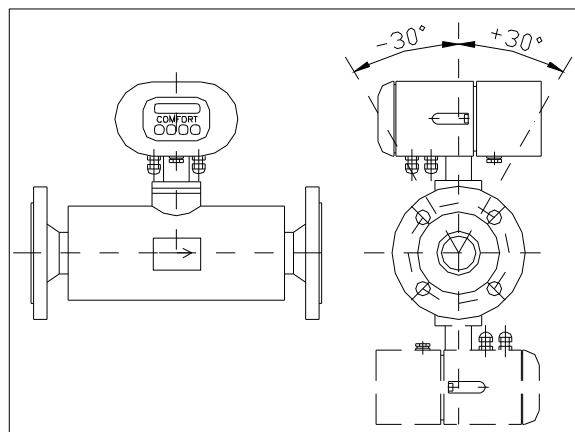

# ***Product application, installation and service manual***

The measured fluid shall be free of larger solid particles and air bubbles either coming into the fluid through leaks in the piping or originating by the cavitation process in the sensor or other piping components. If cavitation is suspected to appear in the sensor or piping, the fluid pressure in the sensor or the respective piping section needs be increased.

The above sensor installation rules apply to both compact version of the flow meter and the separately installed sensor units provided with the terminal boxes (the “split” version of the meter).

In the piping systems used to deliver liquids such as rape-seed oil, black oil, caprolactan or chemical compounds with easily separable components, it is recommended to mount flow meters in a vertical position with the measured fluid flowing upwards. This arrangement ensures better mixing action and homogeneity of the fluid flowing through the meter sensor.

The pressure loss vs. flow rate characteristics of individual sensor models are shown in a table in section 4.3 above. In the cases of commercial (invoicing) meters, the evaluation electronic unit of the meter shall be supplied from the mains (230 V, 50 Hz) by a separate power line with an overcurrent circuit breaker to be sealed at the ON position, where the switching-off actions shall be reserved to duly authorised staff only. The recommended power supply cable is CYKY 3x1.5 mm<sup>2</sup> with the external diameter 10.5 mm, and the associated overcurrent circuit breaker should be rated at 6 A. The recommended cable for the RS 485 communication line is JYTY – Al with laminated foil 2D x 1 mm<sup>2</sup> with a repeater for every 1,000 m of the line.

## **6. METER INSTALLATION GUIDE**

The meter assembly and installation directions given in this manual shall be strictly observed.

To prevent undesirable interference between the power and signal devices, the power cables shall be placed at least 25 cm away from all signal cables (the coaxial cables connecting the sensor with the signal processing electronic circuits in the case of a split version of the meter, the RS 485 communication line and the output signal cables). If a signal cable needs be extended, the cable conductors shall be soldered and the soldered joint protected against environmental and mechanical stresses by a suitable installation box. All cables shall be led outside the thermal insulation layers on the fluid piping. To connect a Pt 100 thermometer, the current output and the RS 485 communication line, use shielded wires with the shield connected to the ground potential terminal on terminal board X1 in the electronic unit box (or X2, see section 6.2 below). Shielded wires are also recommended to be used for the frequency and impulse output signals where the shields should be connected to the ground potential in the superordinated electronic control system.

Sensor must be grounded properly. For grounding use a conductor with minimum cross section area 4 mm<sup>2</sup> and connect the conductor to grounding bolts of evaluation electronic and flow sensor (see figure here below).

# Product application, installation and service manual

Earthing connection between the sensor and the electronic unit (the split version)

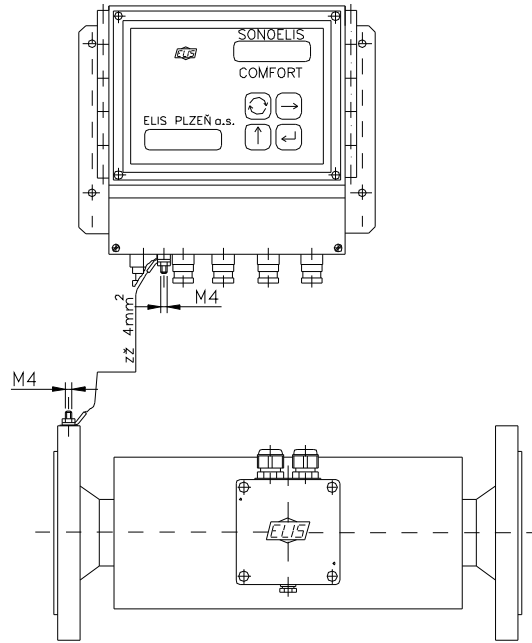

## 6.1. Electronic circuits (the split version)

The electronic signal processing unit shall be mounted in a vertical position on an installation frame. The interconnection between the electronic unit and the meter sensors (UC 3.0 or UC 5.0) is described in section 6.2 below. The connecting coaxial cables should not differ in length by more than 0.1 m.

## 6.2. Electrical connections

A split version of flow meter with flow sensor UC 3.0

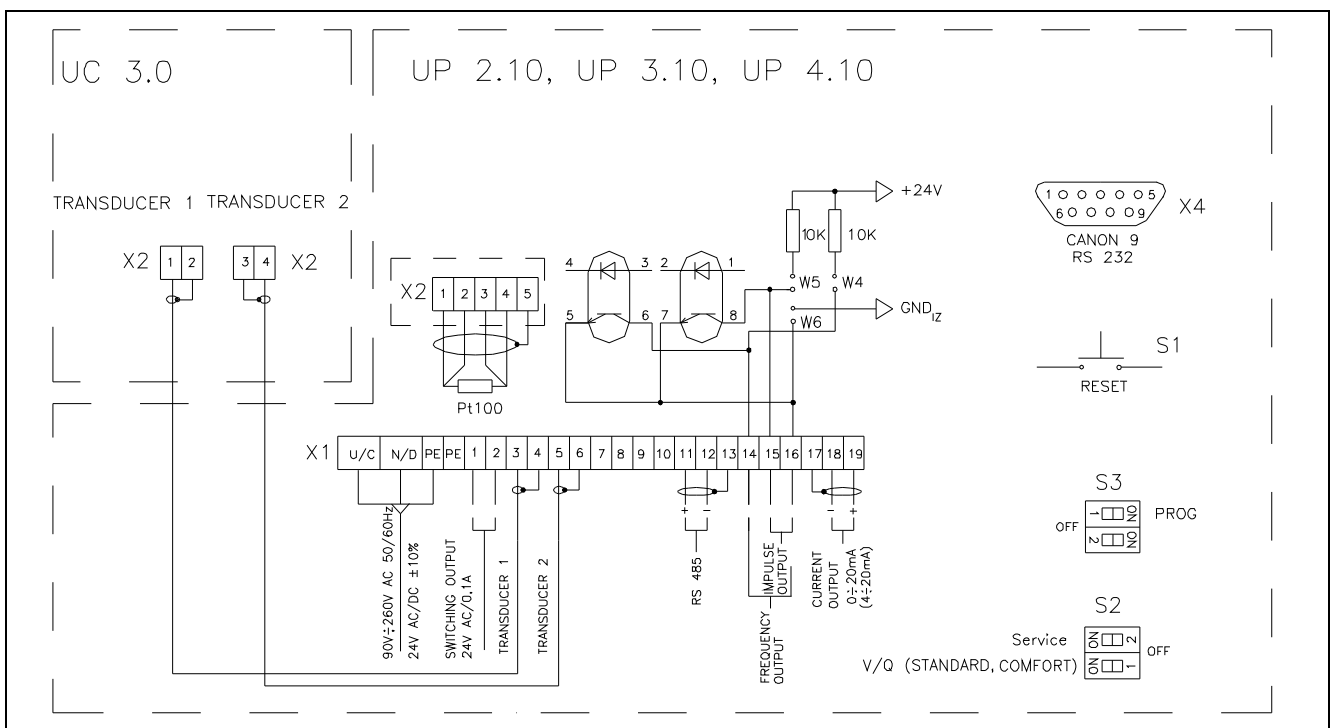

# Product application, installation and service manual

## A split version of flow meter with flow sensor UC 5.0

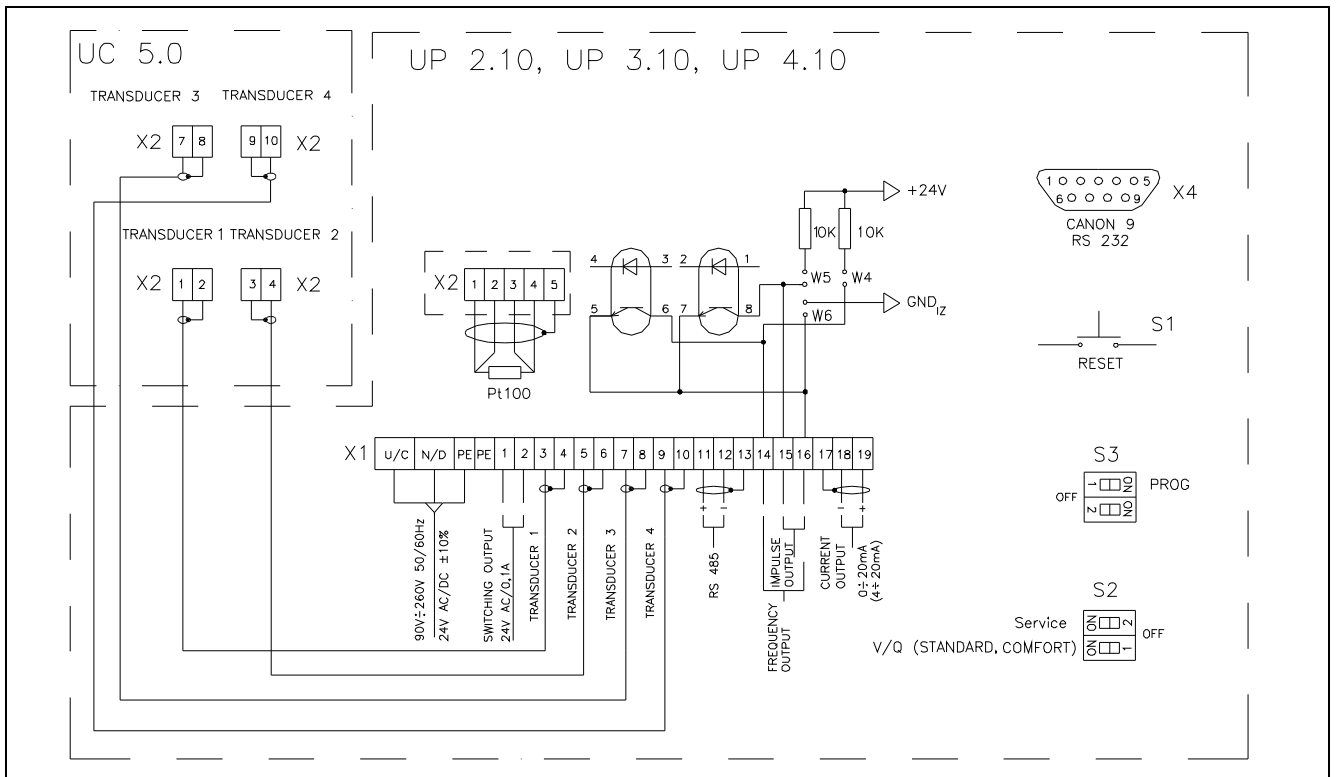

## A compact version of flow meter

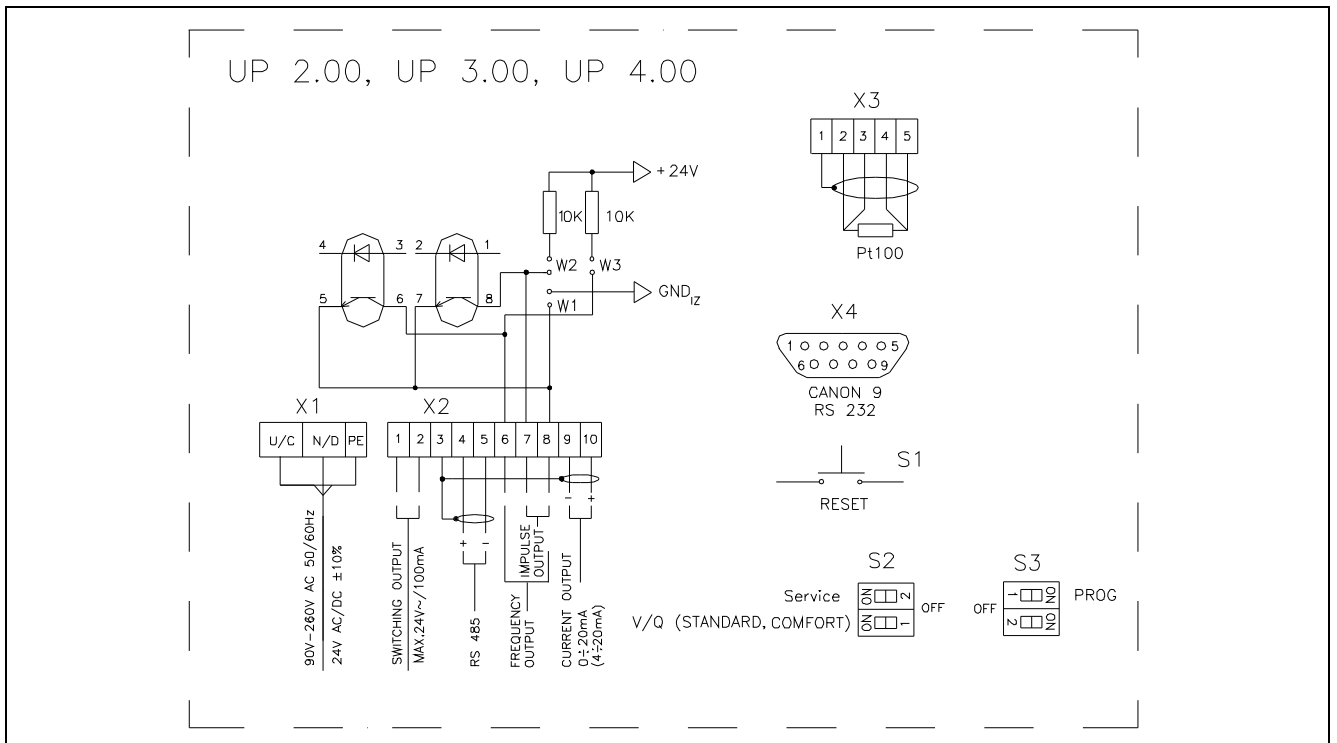

Connector X4 serves the purposes of the equipment calibration, servicing and parameter setting at the manufacturer's plant. The signal outputs (frequency, impulse and current outputs) are isolated and power from a separate isolated power source. The frequency and impulse outputs can be used in either passive or active operational modes, while the current output is always active. In view of the arrangement used (a common power source and therefore the possibility of equalising currents flowing between the

# *Product application, installation and service manual*

outputs), it is recommended not to use more than two outputs in the active mode at any time. If the frequency and/or impulse outputs are used in the passive mode (pins W1 through to W6 are disconnected), the optocoupler current shall not exceed 20 mA. Pushbutton S1, if depressed, resets the data on the aggregate fluid volume that has passed through the flow meter. Terminals 1 and 2 at terminal board X1 (in the case of a split version) or X2 (in the case of a compact version of the meter) can be connected to a relay coil in series with an external AC power source and so provide for indication of the flow direction or other selected parameter status. Thermometer Pt 100, if used, shall be connected to terminals 1 to 5 at terminal board X2 (in the case of a split version) or X3 (in the case of a compact version of the meter). The thermometer signal is used to convert the fluid volume data to mass data in special flow meter configurations. If isolated voltage, frequency or impulse outputs are required, the W-pins shall be connected as shown in the table below:

Type of el. unit	UP 2.00, UP 3.00, UP 4.00	UP 2.10, UP 3.10, UP 4.10
Frequency output	W3 to W1	W4 to W6
Impulse output	W2 to W1	W5 to W6

As shown in the schematic diagrams in section 6.2 above, isolated current outputs 0 to 20 or 4 to 20 mA and an output for the RS 485 communication line are available at specific terminals and can be used according to the requirements of the customer. In the split version of the meter, the ultrasonic sensor is connected to the signal processing unit by two or four coaxial cables (see the schematic diagrams).

If the flow meter is to serve the purposes of a standard/invoicing meter, switch S3 and one section of switch S2 should be sealed and provided with calibration mark. The remaining section of switch S2 (S2:1) may be used to select display of the instantaneous velocity or flow rate of the measured fluid (applies to flow meters in the STANDARD or COMFORT configurations).

The following table shows the control functions of double switches S2 and S3.

Operational modes and combinations of the positions of switches S2 and S3		
Measuring mode	S2:1 position OFF S2:2 position OFF	S3:2 position OFF
Configurations STANDARD and COMFORT: S2:1 position OFF – display shows the flow rate S2:1 position ON – display shows the flow velocity		
Service mode	S2:2 position ON	S3:2 position OFF
Programming mode	S2:2 position OFF	S3:2 position ON

### **6.3. Ultrasonic sensor**

Ultrasonic sensors shall not be covered with thermal insulation. The connecting coaxial cables shall not be attached to piping containing warm fluid. The sensors shall be installed in the piping in such a way as to ensure that the associated electronic unit (in the case of a compact version) or the terminal box (in the split version of the meter) is facing up or down.

The position of the sensor in the piping shall be such that the hydraulic part of the sensor is fully flooded by the measured fluid at all times. If the sensor is installed in a vertical section of the piping, the measured fluid shall only flow in the upward direction. Disregarding these or other sensor installation rules (see section 5) may result in incorrect flow rate or flow volume readings.

# *Product application, installation and service manual*

## **6.4. Mechanical assembly and installation**

Ultrasonic sensors shall be fitted into the piping by means of end flanges (size 11, ČSN EN 1092-1) with suitable counterparts at the piping ends. The internal diameters of the pipe flanges and the piping itself shall be the same as that of the sensor. The pipe flange faces shall be perpendicular to the piping axis. The piping sections including sealing rings at the sensor input and output shall be co-axial with no protruding edges in the flow channel.

The separate box with electronic circuits (in the case of a split version of the meter) shall be attached to a suitable vertical support plate by means of four bolts of diameter 5 mm.

## **7. METER COMMISSIONING AND CONTROL**

### **7.1. The ECONOMIC configuration**

After the meter has been installed in the piping (which implies, in the case of a compact version, installation of the complete meter or, in the case of a split version, installation of the flow sensor in the piping and connecting it to a separate signal processing unit), the meter can be energised. Very soon (within a few seconds) the meter will adopt the measuring (and data display) mode and the frequency, impulse and isolated current outputs will be operative. The impulse and frequency outputs can be used either in the passive mode (where the function is essentially that of a transistor switch with power supplied from the associated equipment) or in the active mode where the output circuits are powered from an internal isolated source. The selection of the output mode of operation is done by connecting or disconnecting the respective W pins (see section 6.2 above).

The aggregate flow volume or mass data transmitted by the RS 485 communication line can be reset either via the communication line or manually, using the RESET push-button located under the terminal board cover.

### **7.2. The STANDARD configuration**

Upon installation of the ultrasonic sensor in the piping and connecting it to the signal processing unit (the split meter version), or installation in the piping of the compact version of the meter, the meter can be energised. After a short initial period during which the system parameters are reset the meter starts measuring and the frequency, impulse and current outputs become operative. Regarding the signal output mode and meter resetting information refer to the previous section 7.1 (the ECONOMIC configuration).

Unlike the ECONOMIC, the STANDARD configuration includes a two-line alphanumeric display of 16 characters per line. The first 15 characters on each line display the measured values, the last character shows the operational status of the meter.

#### **7.2.1. Display data**

The data on the display include selected measured quantities and information on the flow meter operational status.

# *Product application, installation and service manual*

## **7.2.1.1. Meter status information**

The first three seconds after connecting the meter to the power source the display reads

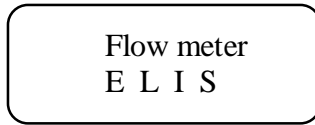

In the normal operation, the symbol appearing at the last digit position on the second line informs about the current mode of operation of the signal processing electronic unit. The characters used and their meanings are as follows:

- I electronic unit initialisation
- + measurements in the positive flow direction
- measurements in the negative flow direction
- C calculation of measured values, output signal generation and display
- W stand-by mode
- T data communication (data being sent).

Under normal operating conditions the above characters regularly replace one another. In the case of an error due to a sensor failure, loss of a sensor signal due to a cable failure, presence of an air bubble or a mechanical particle in the fluid flow, an “R” will appear at the last position on the first line and the “I” and “+” signs will appear in turns at the last position on the second line of the display unit. A failure of the electronic unit will usually be manifested by discontinued regular changes of the system status symbols on the display.

## **7.2.1.2. Display of measured data**

Up to three measured quantities can be displayed simultaneously; one on the first line, and the other two in turns on the second line of the display unit. The switching frequency can be selected in terms of the number of measuring cycles per display time of one measured quantity.

Most often the first display line is used to show the volume flow rate (in m<sup>3</sup>/hod) or the mass flow rate (in metric tons per hour), and the second display line to display the total volume (in m<sup>3</sup>) or the total mass (in metric tons) alternatively with the fluid temperature in °C. However, the customer is free to define other combinations of the data to be displayed and/or to select other optional data units from the software menu available.

## **7.2.2. Review of the measured quantities**

- Volume flow rate
- Relative volume flow rate (in % of  $q_s$ )
- Mass flow rate [T]
- Relative mass flow rate (in % of  $q_s$ ) [T]
- Volume (aggregate value)
- Volume + (volume of the fluid passed in the positive direction) [O]
- Volume - (volume of the fluid passed in the negative direction) [O]
- Mass (aggregate mass) [T]
- Mass + (mass of the fluid passed in the positive direction) [T], [O]
- Mass - (mass of the fluid passed in the negative direction) [T], [O]
- Temperature [T]
- Density [T]

# Product application, installation and service manual

Sound propagation velocity  
 Fluid flow velocity through the sensor flange  
 Start of the measurement period (date and time of the last resetting command)  
 Duration of the measurement period  
 Duration of a meter error condition  
 Duration of a power failure period  
 Date  
 Time

**Comment:**

Quantities denoted [T] will only be measured and displayed if the meter configuration includes a thermometer; quantities denoted [O] require that the flow meter has been set for measurements in both fluid-flow directions.

### 7.2.3. Review of the measured quantity units

Volume flow rate	Mass flow rate	Volume	Mass
m <sup>3</sup> /hour	t/hour	1,000 m <sup>3</sup>	1,000 t
m <sup>3</sup> /min	t/min	m <sup>3</sup>	t
m <sup>3</sup> /s	t/s	l	kg
l/hour	kg/hour	1,000 bbl	1,000 tons
l/min	kg/min	bbl	ton
l/s	kg/s	1,000 ft <sup>3</sup>	lb
bbl/hour	tons/hour	ft <sup>3</sup>	
bbl/min	tons/min	1,000 gal	
bbl/s	tons/s	gal	
ft <sup>3</sup> /hour	lb/hour		
ft <sup>3</sup> /min	lb/min		
ft <sup>3</sup> /s	lb/s		
gal/hour			
gal/min			
gal/s			

Temperature	Density	Velocity
°C	t/m <sup>3</sup>	m/s
°F	kg/m <sup>3</sup>	ft/s
	g/cm <sup>3</sup>	
	tons/m <sup>3</sup>	
	lb/ft <sup>3</sup>	

### Names of selected units

bbl	American barrel
ft	Foot
gal	American gallon
ton	American ton
lb	Pound
m <sup>3</sup>	Cubic meter
l	Litre

s	Second
min	Minute
hour	Hour
°C	Degree Celsius
°F	Degree Fahrenheit
t	Metric ton
kg	Kilogram

# Product application, installation and service manual

## 7.2.4. Unit conversion table

Volume flow rate	1 m <sup>3</sup> /hour =	0.01666667 m <sup>3</sup> /min 0.0002777778 m <sup>3</sup> /s 1,000 l/hour 16.66667 l/min 0.2777778 l/s 6.289387 bbl/hour 0.1048231 bbl/min 0.001747052 bbl/s 35.31467 ft <sup>3</sup> /hour 0.5885778 ft <sup>3</sup> /min 0.009809630 ft <sup>3</sup> /s 264.1708 gal/hour 4.402846 gal/min 0.07338077 gal/s
Mass flow rate	1 t/hour =	1.102311 tons/hour 0.01837185 tons/min 0.0003061975 tons/s 2,204.623 lb/hour 36.74371 lb/min 0.6123952 lb/s
Volume	1 m <sup>3</sup> =	6.289387 bbl 35.31467 ft <sup>3</sup> 264.1708 gal
Mass	1 t =	1.102311 tons 2,204.623 lb
Density	1 t/m <sup>3</sup> =	1.102311 tons/m <sup>3</sup> 62.42797 lb/ft <sup>3</sup>
Temperature	t <sub>F</sub> =	32 + 1.8 t <sub>C</sub>
Velocity	1 m/s =	3.280840 ft/s

## 7.3. The COMFORT configuration

The functions of the flow meter in the COMFORT configuration including the output signals are essentially the same as those described for the STANDARD configuration. However, the four-button keyboard in the COMFORT configuration allows for a wide range of the meter functions to be controlled and modified with respect to the requirements of particular operating conditions at the user's plant. Push-buttons T1 to T4 are provided with the following graphic symbols:



T1

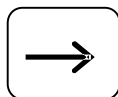

T2



T3

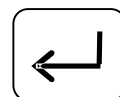

T4

The push-button control of the meter is shown in a schematic diagram in Fig. 7.3.1 (page 33). The system can be operated in two different modes where the switching-over action between the operation modes and individual functional blocks within a selected mode can be initiated by depressing the push-button the image of which is depicted at the given transition position. From the diagram it follows that a transition from one block to the next one (on the right-hand side) will be done by depressing the T2 button, while a transition to the previous block (next on the left-hand side) by depressing the T3 button.

# *Product application, installation and service manual*

The Zero Reset block can only be activated in the cases of technological meters (the software switch in the “NF” position). In the case of commercial (invoicing) meters, where the switch is in the “F” position, the Zero reset block is missing.

Upon energising, the meter will automatically adopt the display mode with the pre-selected (initial) quantity displayed (see description below). The display mode will also become operative if no push-button has been depressed over the period of 300 measurement cycles (5 minutes for a measurement cycle of 1 s).

Any push-button control actions will not disturb the measuring functions of the meter in any way. A detailed description of individual “block” functions controlled by the push-button unit is given in the following paragraphs.

## **7.3.1. Data display mode**

The flow meter in full configuration can measure and evaluate any of the 20 physical quantities listed in section 7.2.2 above. In the data display mode, any of the measured quantities can be displayed. The display format is as follows:

Line 1 – name of the measured quantity in the selected language (Czech, English, German, Spanish, Italian or French);

Line 2 – the measured value in the selected unit system.

Upon switching the power on, the system activates the data display mode whereby the measured value of the pre-selected (“initial”) physical quantity is displayed. Each of the 20 physical quantities available can be selected as the initial one.

If the operator depresses push-button T1, another measured quantity will be displayed (the next on the list in section 7.2.2). Then, unless T1 is depressed again within 5 minutes, the initial quantity will be displayed again.

To leave the Data Display Mode for the Parameter Setting Mode, depress push-button T4 (see Fig. 7.3.2, page 33). Select the desired operating mode (function block) by push-button T1 and confirm the selection by depressing T4 again.

### **7.3.1.1. Volume flow rate**

The value of the measured volume flow rate is displayed as a 3- or 4-digit number (this is determined by the manufacturer with respect to the meter application). Provided the flow meter has been set for measurements in both directions of flow, the sign before the reading indicates the flow direction (“+” for the flow direction shown by the arrow sign on the meter body, “-“ for the opposite direction).

### **7.3.1.2. Relative volume flow rate**

The displayed reading shows the ratio (in per cent) of the measured volume flow rate to the specified maximum volume flow rate.

### **7.3.1.3. Mass flow rate**

The mass flow rate can be measured and the measured data displayed only on condition that the meter configuration includes a thermometer and that the fluid density vs. temperature characteristic is known. For more technical details of the readings see the comments to section 7.3.1.1 above. If a thermometer is not installed, the mass flow rate function block is skipped when selected by push-button T1.

# *Product application, installation and service manual*

## **7.3.1.4. Relative mass flow rate**

See the comments to section 7.3.1.2 above concerning the relative volume flow rate.

## **7.3.1.5. Volume**

The aggregate fluid volume passed through the flow sensor during the measurement period, i.e. from the moment the volume data were reset by the reset push-button on the meter, or since the measurement start command from the superordinated control system was received via the RS 485 communication line, or since the data-resetting command was actuated using the T push-buttons as described in section 7.3.2.8 below. The displayed value can have up to 7 digits; higher readings are shown in the form of products of real numbers and appropriate powers of 10 (the “E” format). The reading sensitivity is 0.01 l, the maximum reading is  $2.8 \cdot 10^9 \text{ m}^3$ . In the case of bi-directional measurement, the aggregate volume reading is the difference between the volume passed in the positive and the negative direction of the fluid flow. The displayed value includes the polarity sign.

## **7.3.1.6. Volume +**

Applicable only in the case of bi-directional measurement. The reading represents the aggregate fluid volume passed in the positive flow direction (see the arrow on the meter body). The reading format and the range of the measured values are as described in section 7.3.1.5 above.

## **7.3.1.7. Volume -**

See section 7.3.1.6, for the reverse flow direction.

## **7.3.1.8. Mass**

See section 7.3.1.5, for the aggregate mass of the fluid passed through the flow sensor. The reading sensitivity is 0.01 kg.

## **7.3.1.9. Mass +**

See section 7.3.1.6, for the aggregate mass flow in the positive direction.

## **7.3.1.10. Mass -**

See section 7.3.1.7, for the aggregate mass flow in the reverse direction.

## **7.3.1.11. Temperature**

The temperature reading is only available if a thermometer is included in the meter configuration. The reading sensitivity is 0.1 °C.

## **7.3.1.12. Density**

The fluid density readings are available provided a thermometer has been installed.

## **7.3.1.13. Sound propagation velocity**

Velocity of the acoustic signal propagating in the measured fluid.

# *Product application, installation and service manual*

## **7.3.1.14. Fluid flow velocity**

Velocity of the fluid passing through the sensor flange.

## **7.3.1.15. Start of the measurement period**

The calendar date, hour and minute when the measurement period commenced (the last resetting of the aggregate flow data).

## **7.3.1.16. Duration of the measurement period**

The length of the period (in hours, minutes and seconds) from the measurement start (see section 7.3.1.15) during which the flow meter continuously performed the flow rate measurements.

## **7.3.1.17. Duration of failure condition**

The total duration of the period(s) (in hours, minutes and seconds) from the measurement start during which the meter was energised but could not perform measurements due to a failure condition.

## **7.3.1.18. Power failure period**

The total duration of the period(s) (in hours, minutes and seconds) from the measurement start during which the meter was not energised.

## **7.3.1.19. Date**

The display shows the actual calendar date.

## **7.3.1.20. Time**

The display shows the actual time of the day.

## **7.3.2. Parameter setting mode**

When selecting the parameter setting mode (see section 7.3.1), the operator will be requested to enter a four-digit password.

### **7.3.2.1 Password**

The first display line will read



PASSWORD

and the first digit position on the second line will display 0. Depress push-button T3 repeatedly to increase the number by 1 at a time (after 9 will follow 0 again). Select the correct number at the first digit position and then depress push-button T2 to move to the second digit position and repeat the number setting procedure with push-button T3. Progress to the third and fourth digit positions and enter the correct password – a combination of four numbers (see the schematic diagram in Fig. 7.3.3, page 34).

Confirm the entry of the correct password by depressing push-button T4. Provided the password entered is correct, the system will proceed to the language selection block. In the case of an incorrect password the system will request a new password entry. After three consecutive entries of incorrect passwords the system will switch over to the data display mode and will not permit further entry into the parameter

# *Product application, installation and service manual*

setting mode. A new attempt at the password entry is only possible after system de-energising and repeated switching on of the power supply.

Should the operator forget the password, it is possible to use the manufacturer's password supplied with the system (0200). This shall be done as follows: switch off the power, depress and hold push-button T4 and switch the power on again.

The user password can be changed at any time in the parameter setting mode using the procedure described in section 7.3.2.5 below.

## **7.3.2.2. Meter setting procedures**

The meter parameters that can be defined or re-defined in the parameter setting mode include: the language of the messages appearing on the display, units of the displayed quantities, the user password required for entry into the parameter setting mode, the initial measured quantity, specified values of some measured quantities ( $q_s$ , impulse number – litres per imp., threshold/sensitivity level, and the maximum/limit values of fluid flow rate, volume and temperature), as well as the date, day of the week, time of the day, start of the measurement period and meter zero position (only with the technological meters).

The procedures to be used in setting particular parameters are described below. Upon initialisation of a particular parameter setting mode, the name of the function block concerned will appear on the first line of the display in block letters, e.g.



LANGUAGE

At the same time, the current parameter name or value will appear on the second line. If you wish to pass on to the next parameter, depress T2; by depressing push-button T3 you will return to the previous parameter. Any parameter changes are done using push-button T1, confirmation of the new value by push-button T4. The display will then read



PARAMETER SET

To leave the current parameter setting mode and proceed to another parameter block, depress push-button T2. If you wish to return to the previous block, depress T3. To leave the parameter setting mode completely (and enter the data display mode for the parameter just set), depress push-button T4.

## **7.3.2.3. Language selection**

The operator can choose from any of the six languages available (see Fig. 7.3.4, page 34). The language setting mode will be initiated as soon as the system acknowledges the correct user password. The first line on the display will then read



LANGUAGE

or a message to the same effect in the actually defined language. On delivery, the language selected will be Czech unless the customer has specified their required language in the product order. The second display line will identify one of the languages available (e.g. Czech). Depress repeatedly push-button T1 to select the desired language. Upon selecting the language, confirm the setting by depressing push-button T4. The message on the display will inform the operator of completion of the parameter setting in the newly selected language.

# *Product application, installation and service manual*

## **7.3.2.4. Measuring unit selection**

In this parameter setting mode, the desired measuring unit can be associated with each measured physical quantity (see Fig. 7.3.5, page 35). Upon initiating this mode, the first line of the display will read



UNITS

while the name a physical quantity will appear on the second line. Depress repeatedly push-button T1 to select the desired quantity and confirm by depressing T4. The quantity name will then appear on the first line and the second line will display one of the measuring units available. Select the desired unit by T1 and confirm by T4. Depress push-button T3 to access another measured quantity or use T2 to proceed to another parameter to be set.

## **7.3.2.5. New password definition**



NEW PASSWORD

In this mode, the operator/user may modify the existing password used to access the parameter setting mode (see Fig. 7.3.6, page 35). Depress push-button T4. The first digit position on the second line will display 0. Set the new password (a combination of four numbers) using the procedure described in section 7.3.2.1 above. Upon final confirmation by depressing push-button T4, the legend Parameter Set will appear on the display. From then on, only the new password will be effective.

## **7.3.2.6. Initial quantity selection**

Upon accessing this parameter setting mode, the first line of the display will read



INITIAL QUANTITY

and the second line will give the quantity's name (see Fig. 7.3.7, page 36). Select the desired initial quantity using push-button T1 and confirm the selection by T4.

## **7.3.2.7. Definition of limit values**



LIMIT VALUE

Here the operator can set altogether 11 (limit) values of parameters. The detailed description of the procedures concerned is shown in Fig. 7.3.8 on page 37. Select the desired parameter by push-button T1 and confirm the selection by T4. The name of the parameter and the associated measuring unit will then appear on the first line of the display and the second line will show the previously defined limit value (with the exception of the date and time). The limit value unit shall always be the same as that selected for data display. For example, if the volume flow rate is displayed in litres per second, the limit value of volume flow rate shall also be defined in l/s. If the mass flow rate measurement mode is selected and the data are displayed in metric tons, the impulse number shall also be defined in t.

Upon depressing push-button T2, the previously set limit value will disappear from the second line and 0 will be displayed in the first digit position. Use push-buttons T3 and T2 to set the digital value and T1 to insert the division signs (a comma in the position of a decimal point, dot in the date and colon in the case of time).

# *Product application, installation and service manual*

The day in the week information is to be set as follows:

- 0 – Sunday
- 1 – Monday
- 2 – Tuesday
- 3 – Wednesday
- 4 – Thursday
- 5 – Friday
- 6 – Saturday

A figure entered may have up to seven digits. The date and time data shall include initial zeroes; e.g. the date of 3 July, 2001 shall be recorded as 03.07.01 and the time 7 minutes past 9 a.m. as 09:07:00. Confirm the selection by depressing push-button T4. In the case of a commercial (invoicing) meter, neither  $q_s$ , impulse number or sensitivity (low flow cutoff) can be reset by the user as these settings are reserved to the duly authorised testing authority. Therefore, for commercial meters, these parameters will not appear on the list of limit values to be reset.

List of parameters (limit values, date and time)

Qmax	Maximum (overload) flow rate $q_s$ in the given measuring units
ICIS	Impulse number, defining fluid volume or mass (in selected units) per one impulse at the impulse output
Date	The actual calendar date
Day of the week	The actual day of the week
Time of the day	The actual time of the day
Low flow cutoff	The flow rate level, in per cent of $q_s$ , below which the meter will display and at its outputs indicate zero flow rate
Vol. flow limit	Maximum volume flow rate level; where a binary output is associated with this parameter, it will indicate values exceeding this limit
Mass flow limit	Maximum mass flow rate; where a binary output is associated with this parameter, it will indicate values exceeding this limit
Volume limit	Maximum aggregate volume; where a binary output is associated with this parameter, it will indicate values exceeding this limit
Mass limit	Maximum aggregate mass; where a binary output is associated with this parameter, it will indicate values exceeding this limit
Temp. limit	Maximum temperature; where a binary output is associated with this parameter, it will indicate values exceeding this limit value.

Comment: The limit values for all the above parameters shall be given in units selected using the procedure described in section 7.3.2.4 above. Should new parameter units be selected, the limit values need be re-defined accordingly; otherwise the meter function would be incorrect.

### **7.3.2.8. Resetting aggregate quantities**

Upon entering this mode, the corresponding message will appear on the display (see Fig. 7.3.9, page 37). If resetting of aggregate quantities is not required, depress push-button T2 to access the next parameter-setting block. Confirm your intention to reset the aggregate quantities by depressing T4. The display will then ask



At this stage, you can still return to the initial step of the resetting mode by depressing T3. Depress T4 to reset the aggregate readings of the flow volume and flow mass, the operational information (the meter operation time, the error time and power loss time) and define the start of a new measurement period (the date, hour and minute of the same). The system will respond with a confirming message (Parameter Set).

# *Product application, installation and service manual*

## **7.3.2.9. Meter zero setting**

Before leaving the manufacturing plant, every flow meter is carefully set for correct operation. One of the key parameters in this respect is the meter zero. A correctly set meter zero implies that at zero flow rate (or zero fluid flow velocity through the meter sensor) the meter indicates a zero flow rate (zero fluid flow velocity). The setting value (a meter zero shift) is expressed in mm per second. The meter zero shift as identified in the manufacturing plant is stored in the meter memory under the name of initial (in-production) zero setting value.

Meter component ageing and other factors acting over long-term operational periods may result in minor meter zero displacements. To eliminate these, use the automated zero resetting function. However, great care should be taken in employing this function. First of all, the zero flow rate condition shall be ensured (make sure that the closing valve in the piping is not leaking). Only then the zero resetting function may be used.

A detailed description of the zero resetting block is shown in Fig. 7.3.10 on page 38. Upon initiating this function, the operator shall select either the in-production or automated meter zero setting mode. The selection is done by push-button T1, confirmation by T4. When the in-production setting mode is selected, the meter zero is reset using the zero shift value determined in the manufacturing plant.

In the automated zero setting mode, the meter will first ask whether the fluid flow rate through the meter sensor is really zero (the main requirement for a successful zero setting). If it is not so, cancel the setting process using push-button T3. Upon confirmation by push-button T4 the display will show the message “WAIT FOR 100”. The zero setting procedure lasts 100 measuring cycles. The actual number of measuring cycles performed is shown on the second display line.

After 100 measuring cycles the zero displacement is evaluated. If it is smaller than 50 mm/s, the shift value is stored and the display will read “PARAMETER SET”. If the value is greater than 50 mm/s, a notice to this effect is displayed. However, this is highly unlikely; in such a case it is recommended to check again whether the fluid flow has indeed been completely stopped. Use push-button T3 to invalidate the setting and push-button T4 to run the setting procedure anew.

The meter zero setting function is available only with technological flow meters.

## **7.3.2.10. End of parameter setting**

At the end of the parameter setting procedure, the display will read



PAR. SETTING END

Depress push-button T4 to access the data display mode. However, should you wish to perform any additional parameter setting action, depress T3 to return to the previous parameter setting function block (see Fig. 7.3.11, page 38).

## **7.4. Automated meter test**

The test can only be used with the STANDARD and COMFORT meter configurations. Its purpose is to handle extraordinary situations where the meter function is incorrect although all operational conditions are within specified limits.

# *Product application, installation and service manual*

Prior to initialising the test, check the correct interconnection between the evaluation electronic unit and the meter sensor, the power supply line, the full sensor flooding and zero flow rate. Then switch off the power, depress push-button S1 (resetting the aggregate volume) and, with S1 depressed, switch on the power again. Upon releasing S1, the display will read

TEST  
SENSOR FULL?

Depress and release S1 again, whereby, provided the sensor is fully flooded, the following message will appear on the display:

LIQUID  
DOES NOT FLOW?

Check the zero flow rate condition and depress and release S1. The test will continue by checking whether the passage route for the ultrasonic ray in one direction is free. The display will read

TEST  
UTS THROUGH.1

If this test is successful, the message “OK” will appear on the display for four seconds, whereby a test of the ray passage route in the other direction will commence.

TEST  
UTS THROUGH.2

After successfully passing this test section, the display will show the amplification values associated with the ultrasonic ray passage in both directions; e.g..

UTS THROUGHPUT  
D1 = 4,56    D2 = 4,55

Under normal circumstances, the amplification values should be between 4.50 and 4.60, and their difference should not exceed 0.10.

After four seconds, the measurement of the ultrasonic wave propagation velocity will commence. The message on the first display line will read:

UTS RATE

After the velocity measurement, which takes approximately 1 s, the measured value will appear on the second line, e.g.

1510.6 m/s

# *Product application, installation and service manual*

If the measured value lies within the limits specified for the given fluid, the following message will appear on the display

RATE LIMITS OK  
END OF TEST

and, after another 4 seconds, the meter will resume the normal measurement mode.

Should a fault be indicated at the ray passage test stage, the display will show ER instead of OK. After 4 seconds, automated probe cleaning procedure will start and last for 5 minutes. The display will then read

CLEAN.UTSP 5 MIN  
11111111 .....

On the second line is displayed step by step, the actual number of the minute of the cleaning procedure is displayed. Every fourth seconds one numeral is added, the line will be filled up by 15 same numbers within 1 minute, after elapsing this time the displayed numbers disappear and next new numbers start to display for a time 1 minute. After the probe cleaning, another ray passage test is performed. Should even then the test result be negative, the following message will appear on the display:

DEFECT  
END OF TEST

The meter needs be put out of service and either sent for repair to the manufacturing plant or a service technician be asked to come and repair the meter on site.

Should a fault be indicated at the ultrasonic wave propagation velocity measurement and the measured velocity lie outside the range of physically defined limits ( $V_{UTS} < 900$  m/s,  $V_{UTS} > 1700$  m/s), the probe cleaning procedure will be initiated (unless it has already been performed) and the velocity measurement will be repeated. Should even then the test result be unsatisfactory, the display will read:

DEFECT  
END OF TEST

and the test sequence will be terminated.

Should the measured velocity lie outside preset limits but within the range of physically possible values, the following message will appear on the display

UTS RATE LIMITS  
ADJUSTMENT

and the actual limits will automatically be re-adjusted with respect to the measured value. The display will in that case read

RATE LIMITS OK  
END OF TEST

and, after another 4 seconds, the meter will resume the normal measurement mode.

Should the meter function still be unsatisfactory, it is possible to repeat the tests. In the case of repeated failure to set the meter right, contact the meter manufacturer.

# Product application, installation and service manual

## PUSH-BUTTON CONTROL OF THE FLOW METER FUNCTIONS

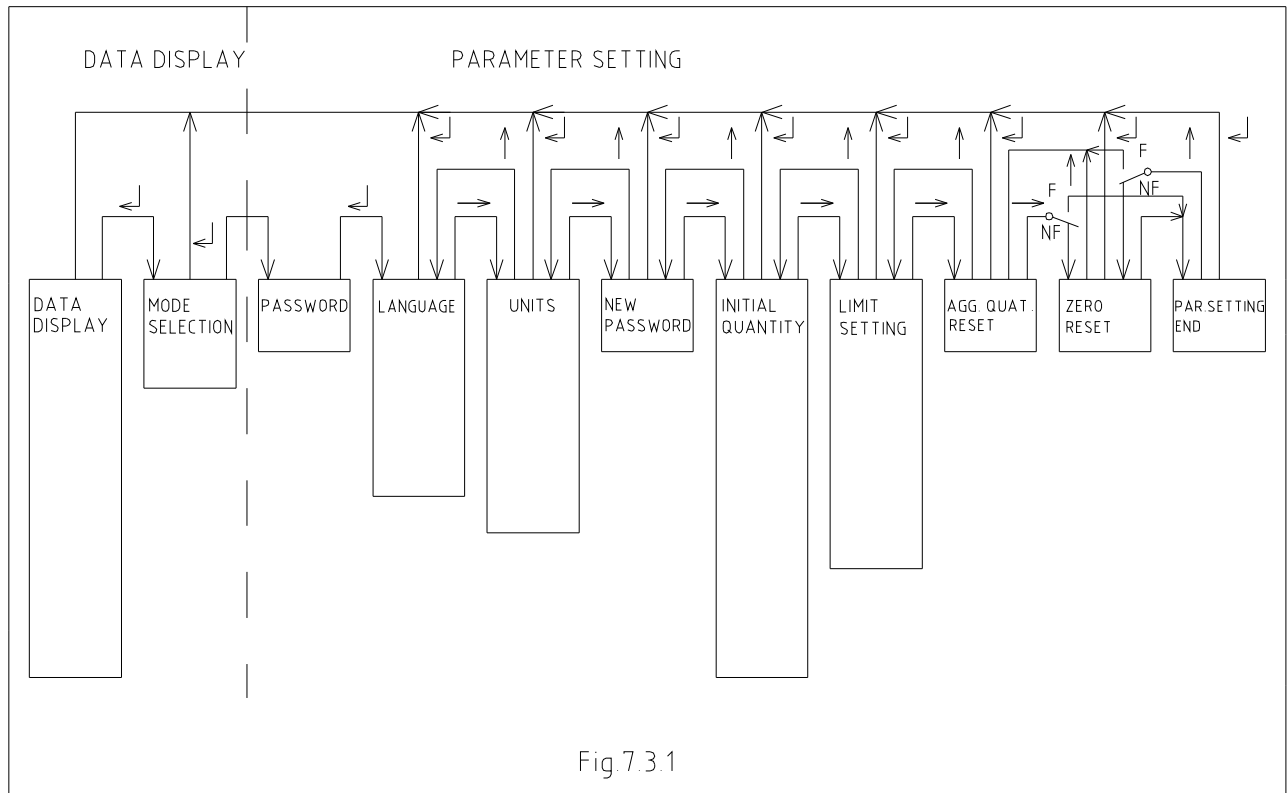

Fig.7.3.1

## DATA DISPLAY

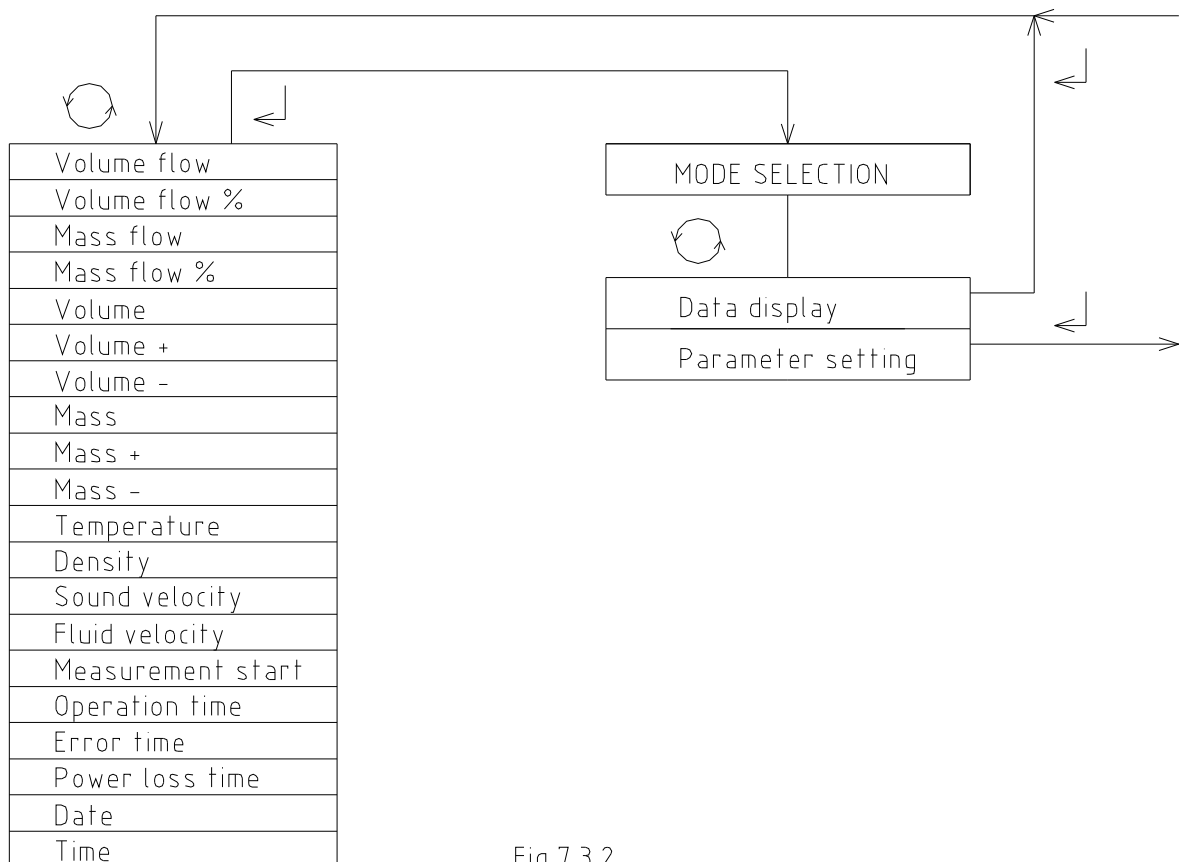

Fig.7.3.2



# Product application, installation and service manual

## MEASURING UNIT SELECTION

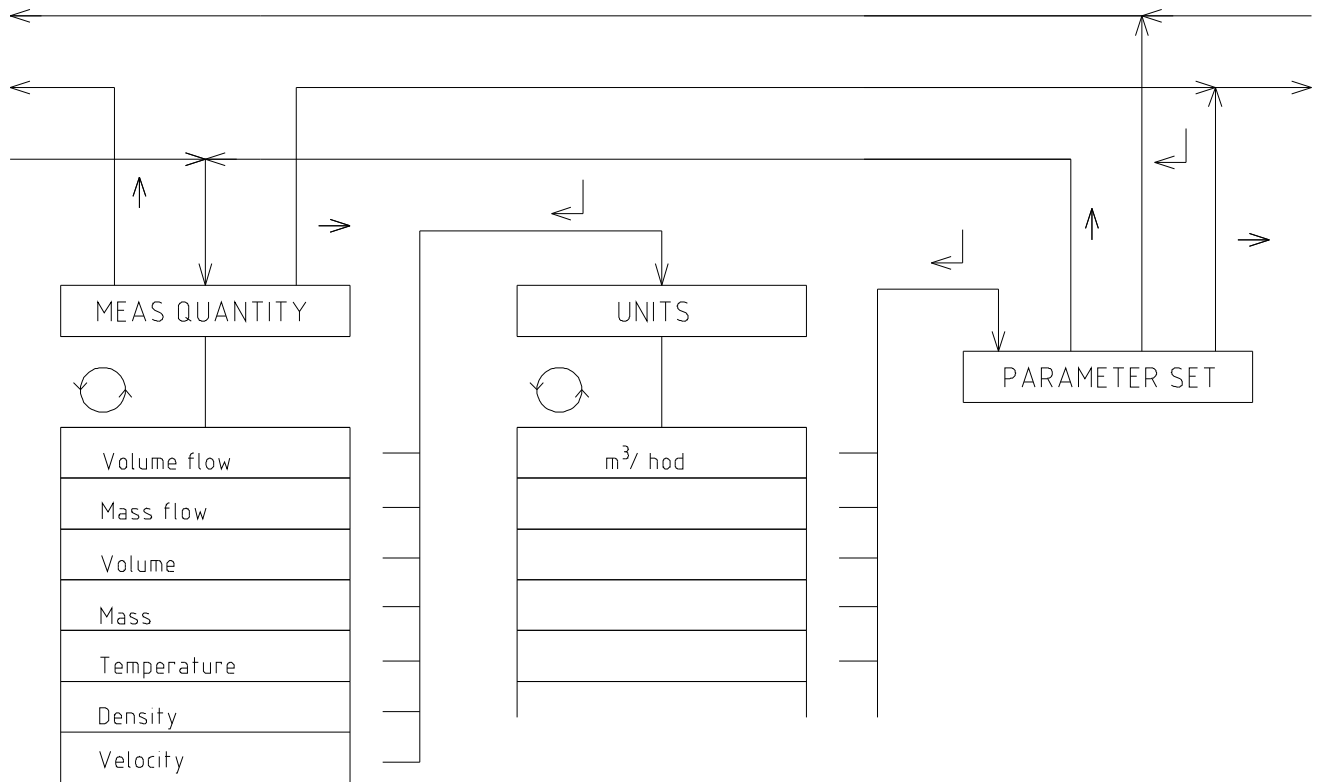

Fig.7.3.5

## NEW PASSWORD DEFINITION

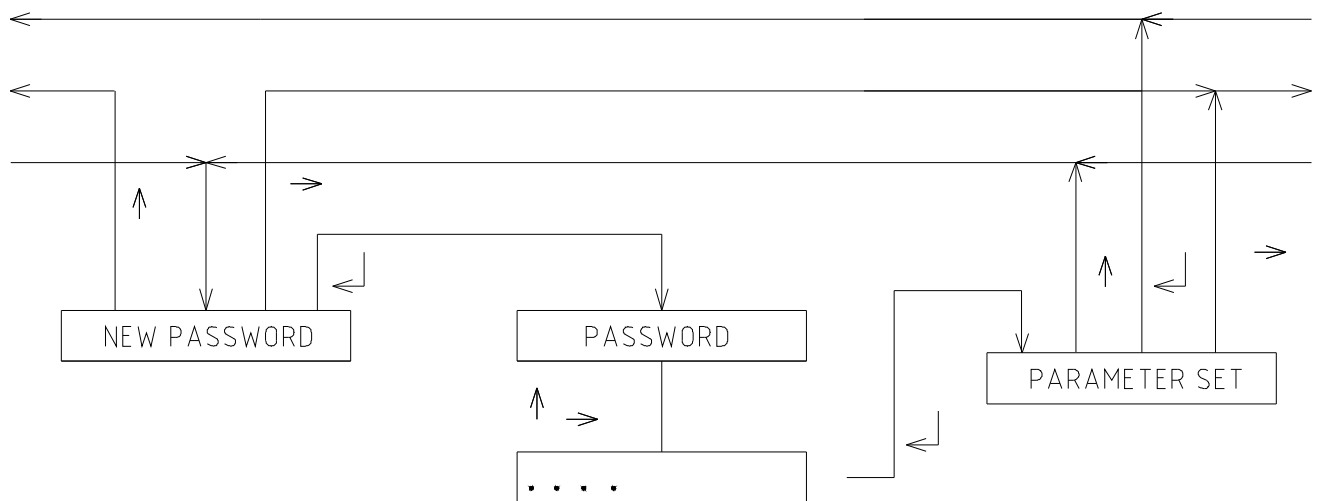

Fig.7.3.6

# Product application, installation and service manual

## INITIAL QUANTITY

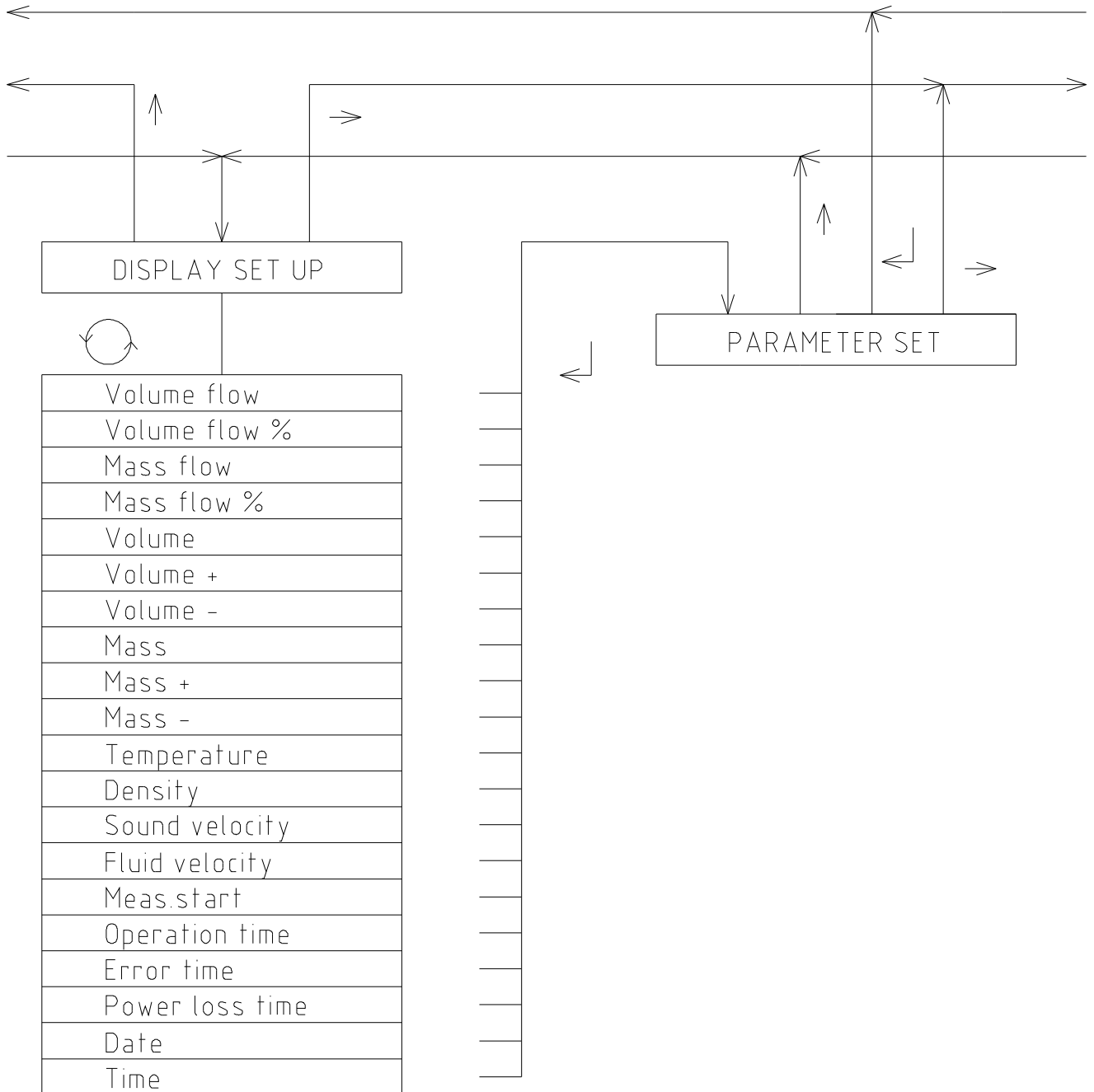

Fig.7.3.7

DEFINITION OF LIMIT VALUES

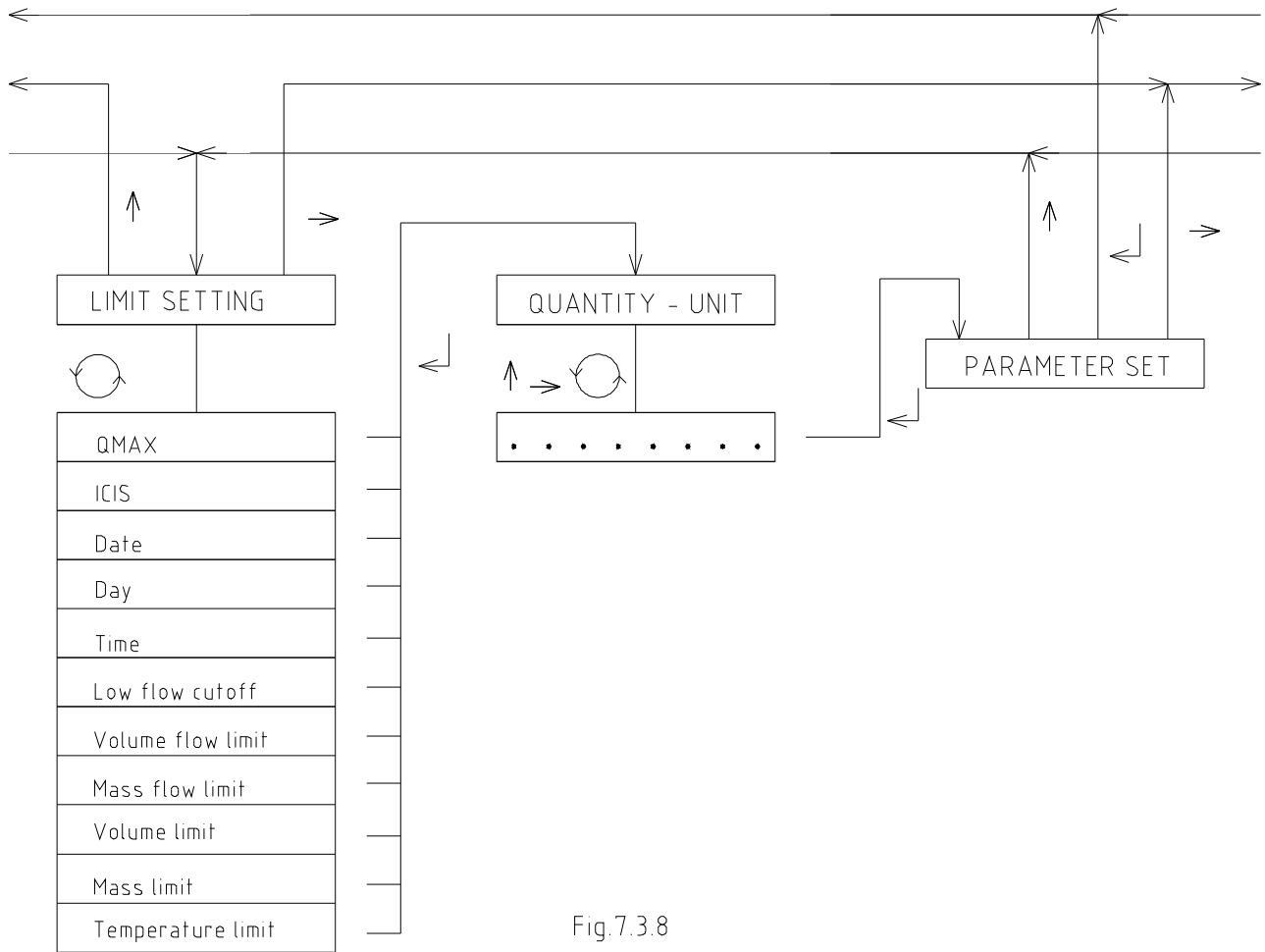

Fig.7.3.8

RESETTING AGGREGATE VALUES

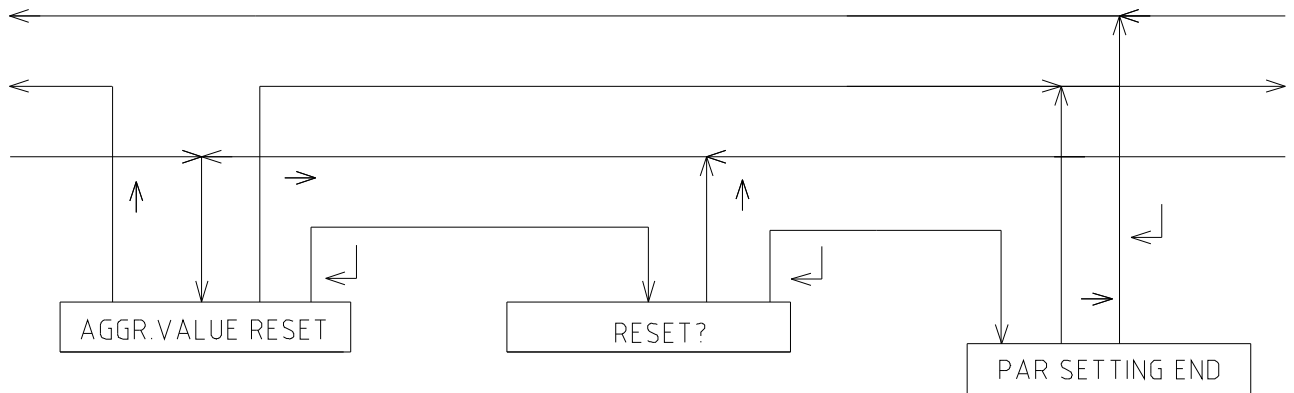

Fig.7.3.9

METER ZERO SETTING

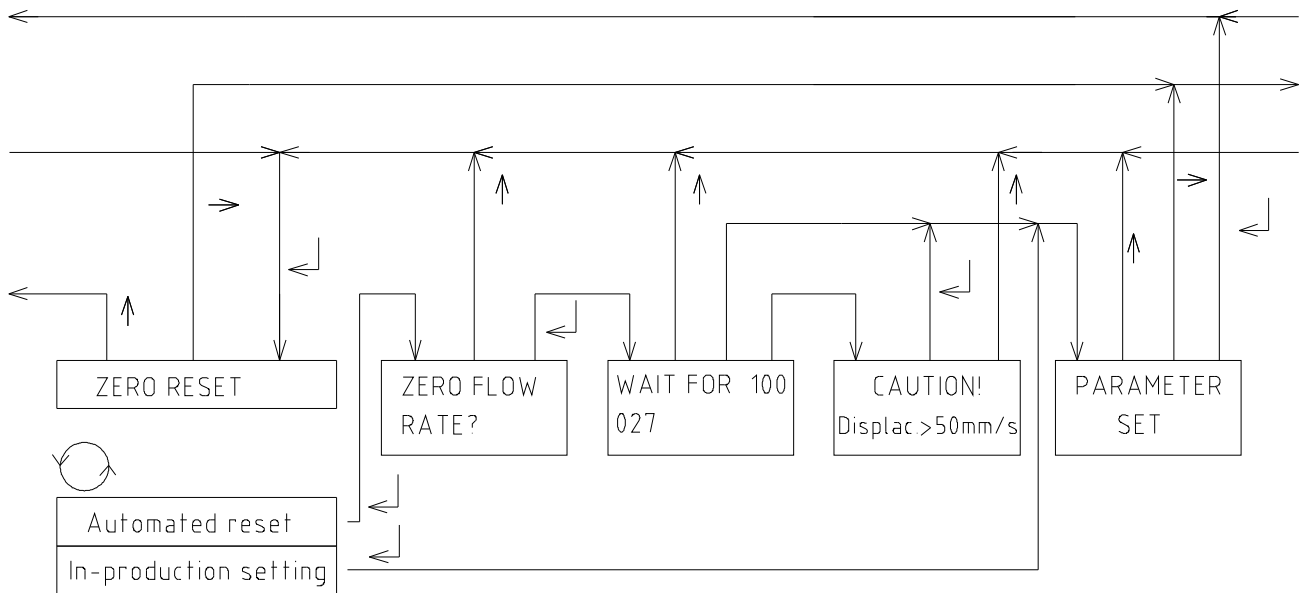

Fig.7.3.10

PARAMETER SETTING END

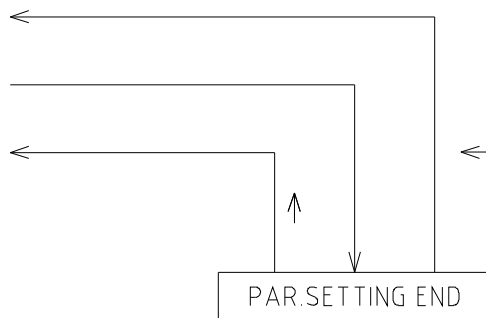

Fig.7.3.11

# *Product application, installation and service manual*

## **8. SERVICE ACTIVITIES**

### **8.1. Warranty services**

The product warranty services are understood to include any repair work executed free of charge either on site or at the manufacturer's premises during the product warranty period. Warranty repairs shall concern product defects due to the use of non-standard materials, parts or design errors. Should such defects prove irreparable, the product shall be replaced at no costs to the customer.

Any warranty repairs shall be performed either by the manufacturer (ELIS PLZEŇ a.s.) or other duly authorised distribution agents or service centres.

#### **The manufacturer's warranty shall not cover**

- products where the installation and/or metrological seals have been removed
- product defects due to incorrect installation
- product defects due to non-standard product use
- product pilferage
- product defects due to circumstances classified as force majeure.

Any requirement for warranty repair shall be submitted in writing (using fax, electronic mail or registered letter) to the official address of the manufacturer. Should the manufacturer establish that the subject product repair does not fall within the warranty conditions, this fact will be made known to the customer in writing and the respective repair costs will be invoiced to the customer. In the case of a commercial meter, the parameters of a repaired product shall be verified at a duly authorised metrological centre.

### **8.2. Post-warranty services**

The post-warranty services are understood to include any repair work necessitated by the product defects or deficiencies identified after the warranty period. All such repair work, whether executed at the manufacturer's plant or on site, shall be invoiced and paid for by the customer. In the case of a commercial meter, the parameters of a repaired product shall be verified at a duly authorised metrological centre. Any requirement for post-warranty repair shall be submitted in writing (using fax, electronic mail or registered letter) to the official address of the manufacturer.

## **9. STANDARD TESTS**

Each finished product is thoroughly checked to establish the product completeness and compliance with the manufacturer's quality assurance standards. Subsequently the product functions are tested according to the specifications of the approved test directions and subject to at least 15-hour burn-in operation cycle.

## **10. VERIFICATION TESTS**

In the case of a commercial (invoicing) meter, the manufacturer shall provide for initial product testing at a duly authorised Metrological Centre. There the meter functions and accuracy are verified under three different operational conditions within the specified range of the fluid flow rate. Upon agreement with the customer and/or in the cases of higher accuracy requirements, the scope of tests can be extended up to nine verification tests under different operational conditions.

# ***Product application, installation and service manual***

**Important notice:** The verification tests on the flow meters SE 404X a SE 406X are recommended to be executed on a running-start testing facility.

## **11. PACKAGING**

The product packaging shall meet the requirements regarding safe domestic and international transport or other conditions agreed to with the customer. In that, the manufacturer uses its own in-company packaging directions and standards.

## **12. PRODUCT ACCEPTANCE PROCEDURE**

The product acceptance procedure consists of visual inspection and check on the completeness of the delivered items with reference to the delivery note. Each shipment of flow meters SE 404X and SE 406X shall include a delivery note, operation and maintenance manuals and a statement on the product compliance with the respective standards.

## **13. WARRANTY CONDITIONS**

Unless agreed otherwise between the manufacturer and the customer, the warranty period for the SONOELIS flow meters is 12 months from the delivery date. Within the warranty period, the manufacturer shall repair, free of charge, any product defects due to faulty materials or parts. In the case of a warranty repair, the warranty period shall be extended by the time the flow meter was inoperative because of such repair. Manufacturer's warranty shall not cover product defects or malfunctions due to incorrect product installation, operation, intentional damage, pilferage or damage due to force majeure circumstances.

## **14. PRODUCT ORDERING**

When ordering the SONOELIC ultrasonic flow meters, use a specific order number to be determined on the basis of the following table. This table can also be found on the Internet address [www.elis.cz](http://www.elis.cz) or in the product manual no. Es 90 204 K.

# Product application, installation and service manual

Number sequence of order number		1	2	3	4	5	6	-	7	8	9	10	11	12
ORDER NUMBER		S	E	4	0									
<b>TYPE OF MODEL</b>														
Type of sensor	one beam	4												
	dual beam	6												
Flow meter design and equipment	ECONOMIC, compact	0												
	ECONOMIC, remote	1												
	STANDARD, compact	2												
	STANDARD, remote	3												
	COMFORT, compact	4												
	COMFORT, remote	5												
<b>SPECIFICATIONS</b>														
Dimension of sensor DN/nominal flow rate $q_p$	32/10	0										1		
	40/16	0										2		
	50/25	0										3		
	65/40	0										4		
	80/75	0										5		
	100/120	0										6		
DN [mm] $q_p$ [m <sup>3</sup> /h, t/h]	125/175	0										7		
	150/250	0										8		
	200/450	0										9		
	250/700	1										0		
	300/1000	1										1		
	non-standard	0										0		
Flanges	ČSN EN 1092-1											1		
	ANSI B 16.5											2		
	BS 4504											3		
	JIS B 2210											4		
	non-standard											0		
Material of sensor, finish	carbon steel, stainless steel, outside painting											1		
	complete stainless steel											2		
	non-standard											0		
Nominal pressure PN	16											1		
	40											2		
	non-standard											0		
$T_{max}$ of measurement medium [°C]	50											1		
	<b>90</b>											<b>2</b>		
	130											3		
	150											4		
	180											5		
	non-standard											0		

# Product application, installation and service manual

Number sequence of order number		-	13	14	15	-	16	17	18	19
ORDER NUMBER										
Lenght of cable for remote version [m]	3		0	1						
	<b>5</b>		<b>0</b>	<b>2</b>						
	7		0	3						
	10		0	4						
	15		0	5						
	20		0	6						
	30		0	7						
	40		0	8						
	50		0	9						
	60		1	0						
	70		1	1						
	80		1	2						
	90		1	3						
	100		1	4						
non-standard		0	0							
Supply	<b>230 V AC, 50/60 Hz</b>				<b>1</b>					
	110 V AC, 50/60 Hz				2					
	24 V AC, 50/60 Hz				3					
	24 V DC				4					
	non-standard				0					
<b>MEASURE</b> <b>D</b> medium	<b>water</b>					<b>0</b>	<b>1</b>			
	oil					0	2			
	petroleum					0	3			
	caprolactam					0	4			
	toluene					0	5			
	phenol					0	6			
	formaldehyde					0	7			
	liquid ammonium					0	8			
	cacao butter					0	9			
	brown coal generator fat					1	0			
	vegetable fat					1	1			
	transformer oil ITO 100, ITO 200, TECHNO 2000, TECHNO 3000					1	2			
	mazout					1	3			
	spirit					1	4			
	non-standard					0	0			
Sort of measurement	one-way, volume									1
	one-way, mass									2
	two-way, volume									3
	two-way, mass									4
	non-standard									0
Non-sensitivity of measurement	standard $q_{NEC}$ according to manual									1
	<b>standard <math>\pm 10</math> mm/s</b>									<b>2</b>
	standard $\pm 0.3\%$ $q_p$									3
	non-standard									0

# Product application, installation and service manual

Number sequence of order number		-	20	21	22	23	24	25	26
ORDER NUMBER									
<b>Pulse output</b>	not required		1						
	0,01 l/imp / 0,01 kg/imp		2						
	0,1 l/imp / 0,1 kg/imp		3						
	1 l/imp / 1 kg/imp		4						
	10 l/imp / 10 kg/imp		5						
	100 l/imp / 100 kg/imp		6						
	1 m <sup>3</sup> /imp / 1 t/imp		7						
	10 m <sup>3</sup> /imp / 10 t/imp		8						
	100 m <sup>3</sup> /imp / 100 t/imp		9						
	non-standard		0						
<b>Frequency output</b>	not required			1					
	0 ÷ q <sub>s</sub> ~ 0 ÷ 500 Hz			2					
	<b>0 ÷ q<sub>s</sub> ~ 0 ÷ 1 kHz</b>			<b>3</b>					
	0 ÷ q <sub>s</sub> ~ 0 ÷ 5 kHz			4					
	0 ÷ q <sub>s</sub> ~ 0 ÷ 10 kHz			5					
	non-standard			0					
<b>Current output</b>	not required				1				
	0 ÷ q <sub>s</sub> ~ 0 ÷ 20 mA				2				
	<b>0 ÷ q<sub>s</sub> ~ 4 ÷ 20 mA</b>				<b>3</b>				
	0 ÷ q <sub>s</sub> ~ 0 ÷ 24 mA				4				
	0 ÷ q <sub>s</sub> ~ 4 ÷ 24 mA				5				
	non-standard				0				
<b>Binary output</b>	not required					0	1		
	fluid flow direction	upstream switch on				0	2		
	fluid flow direction	upstream switch off				0	3		
	total fluid volume level	on exceeding switch on				0	4		
	total fluid volume level	on exceeding switch off				0	5		
	total fluid mass level	on exceeding switch on				0	6		
	total fluid mass level	on exceeding switch off				0	7		
	volume level	on exceeding switch on				0	8		
	volume level	on exceeding switch off				0	9		
	mass level	on exceeding switch on				1	0		
	mass level	on exceeding switch off				1	1		
	temperature level	on exceeding switch on				1	2		
	temperature level	on exceeding switch off				1	3		
	non-completely filled piping, failure	on failure switch on				1	4		
	non-completely filled piping, failure	on failure switch off				1	5		
	non-standard output					0	0		
<b>Display 1<sup>st</sup> line</b>	volume flow							1	
	mass flow							2	
	non-standard variable							0	
<b>Display 2<sup>nd</sup> line</b>	volume								1
	mass								2
	volume + temperature								3
	mass + temperature								4
	non-standard variable								0

# Product application, installation and service manual

Number sequence of order number		-	27	28	29	30	31	32	33	34	-	35
ORDER NUMBER												
<b>Units of volume flow</b>	flow is not pictured	0	1									
	<b>m<sup>3</sup>/h</b>	<b>0</b>	<b>2</b>									
	m <sup>3</sup> /min	0	3									
	m <sup>3</sup> /s	0	4									
	l/h	0	5									
	l/min	0	6									
	l/s	0	7									
	bbbl/h	0	8									
	bbbl/min	0	9									
	bbbl/s	1	0									
	ft <sup>3</sup> /h	1	1									
	ft <sup>3</sup> /min	1	2									
	ft <sup>3</sup> /s	1	3									
	gal/h	1	4									
	gal/min	1	5									
	gal/s	1	6									
	% q <sub>p</sub>	1	7									
non-standard	0	0										
<b>Units of volume</b>	volume is not pictured				1							
	<b>m<sup>3</sup></b>				<b>2</b>							
	m <sup>3</sup> · 10 <sup>3</sup>				3							
	l				4							
	bbbl (US barrel)				5							
	ft <sup>3</sup> (cubic feet)				6							
	gal (US gallon)				7							
	non-standard				0							
<b>Units of mass flow</b>	flow is not pictured					0	1					
	<b>t/h</b>					<b>0</b>	<b>2</b>					
	t/min					0	3					
	t/s					0	4					
	kg/h					0	5					
	kg/min					0	6					
	kg/s					0	7					
	ton/h					0	8					
	ton/min					0	9					
	ton/s					1	0					
	lb/h					1	1					
	lb/min					1	2					
	lb/s					1	3					
	% q <sub>p</sub>					1	4					
non-standard					0	0						
<b>Units of mass</b>	mass isn't pictured									1		
	<b>t</b>									<b>2</b>		
	t · 10 <sup>3</sup>									3		
	kg									4		
	ton (US ton)									5		
	lb (libra)									6		
	non-standard									0		
<b>Units of temperature</b>	<b>°C</b>									<b>1</b>		
	<b>°F</b>									2		
<b>Units of speed</b>	<b>m/s</b>										<b>1</b>	
	<b>ft/s</b>										2	
<b>Language</b>	<b>Czech</b>											<b>1</b>
	English											2
	German											3
	Spanish											4
	Italian											5
	French											6

# Product application, installation and service manual

Number sequence of order number		-	36	37	38	39	40	41	42	43	-	44	45
ORDER NUMBER													
C O M M U N I C A T I O N	<b>RATE</b>	communication is not required	0										
	[Bd]	600	1										
		1200	2										
		2400	3										
		4800	4										
	<b>Parity</b>	no parity np	1										
	<b>transmitter</b>	even – odd eo	2										
	<b>receiver of</b>	odd – even oe	3										
	<b>flow meter</b>	even – even ee	4										
		odd – odd oo	5										
	<b>Group</b>	000			0	0	0						
		001			0	0	1						
		002			0	0	2						
		.					.						
		.					.						
		.					.						
		255			2	5	5						
	<b>Address</b>	000						0	0	0			
		001						0	0	1			
		002						0	0	2			
	.								.				
	.								.				
	.								.				
	255						2	5	5				

## CALIBRATION, METROLOGICAL VERIFICATION

<b>Calibration</b>	without calibration	1
	<b>standard calibration in 3 points without calibrated protocol</b>	<b>2</b>
	standard calibration in 3 points with calibrated protocol	3
	over standard calibration in 5 points without calibrated protocol	4
	over standard calibration in 5 points with calibrated protocol	5
	over standard calibration in 9 points without calibrated protocol	6
	over standard calibration in 9 points with calibrated protocol	7
	standard calibration for metrological verification	8
	non-standard calibration	0
<b>Metrological verification</b>	without metrological verification	1
	metrological verification without protocol	2
	metrological verification with protocol	3
	no-standard metrological verification	0

# Product application, installation and service manual

Number sequence of order number		-	46	47	48	49	50	51	52	53
ORDER NUMBER										
<b>DELIVERY TERMS</b>										
Number of pieces	1 piece	0	0	1						
	2 pieces	0	0	2						
	3 pieces	0	0	3						
	.	.	.	.						
	.	.	.	.						
	999 pieces	9	9	9						
1000 pieces or more	0	0	0							
Packing	no-packing							1		
	<b>standard</b>							<b>2</b>		
	export							3		
	non-standard							0		
Sort of expedition	personal removal							1		
	transport company on cost of seller							2		
	<b>transport company on cost of buyer</b>							<b>3</b>		
	non-standard							0		
Warranty	6 months								1	
	<b>12 months</b>								<b>2</b>	
	18 months								3	
	24 months								4	
	36 months								5	
	non-standard								0	
Register number of manual for define of order number	Es 90 204 K								0	1