



COMMON U.K.

P.O. Box 77

SUTTON COLDFIELD

West Midlands, B73 6SX

tel: +44 (0)121 327 7771

fax: +44 (0)121 327 1117

commonuk@btconnect.com

CPT-01

QUANTOMETERS

OPERATING INSTRUCTIONS



IU:CPT/EN/01/02.06

**PRIOR TO INSTALLATION AND START-UP READ CAREFULLY
THESE INSTRUCTIONS**

Contents

	<i>Page</i>
<i>I. DESIGN AND APPLICATION CONDITIONS</i>	<i>2</i>
<i>II. CONSTRUCTION AND OPERATION</i>	<i>5</i>
<i>III. INDEX AND MEASUREMENT OUTPUTS</i>	<i>6</i>
<i>IV. MARKING AND CALIBRATION OF QUANTOMETERS</i>	<i>11</i>
<i>V. PACKAGING, TRANSPORTATION AND STORAGE</i>	<i>13</i>
<i>VI. INSTALLATION AND START-UP</i>	<i>13</i>
<i>VII. MAINTENANCE, FAULTS , REPAIRS</i>	<i>17</i>
<i>VIII. AUXILIARY EQUIPMENT</i>	<i>17</i>

I. DESIGN AND APPLICATION CONDITIONS

Design

CPT-01 Turbine Quantometers are instruments used for measurement of gas volume that flows through an installation. Standard execution allows to be installed where explosion hazard zones may occur (air and gas mixtures - class IIA and class IIB; with special execution – also class IIC). The CPT-01 Quantometers may be used for measurement of gases indicated in Table 1. Using the CPT-01 Quantometers for measurement of other gases has to be agreed with the manufacturer. Maximum operating pressure for the CPT-01 Quantometers is 2 MPa. The quantometers are installed between the existing flanges.

It is recommended to install the gas meters in compartments with stable temperature, but they are also suitable for outdoor installations. When installed outdoors they should be protected against direct influence of atmospheric conditions (in steel containers, cabinets, under roofs, shields, etc.). The meters may be used at ambient temperature range from -25°C up to $+70^{\circ}\text{C}$; gas temperature range is from -20°C up to $+60^{\circ}\text{C}$.

Application conditions of CPT-01 Quantometers.



1. Conformity with the requirements of the ATEX Directive 94/9/EC:
 - certificate KDB 04ATEX035,
 - CE marking **CE** 1453,
 - application conditions standard execution  II 2G EEx ia IIB T4
special execution  II 2G EEx ia IIC T4
 - index housing protection IP65,
 - harmonised standards PN-EN 13463-1:2003, PN-EN 50014:2002 (U),
PN-EN 50020:2003 (U)
2. Conformity with the requirements of the PED Directive 97/23/EC:
 - certificate 67/JN/2004-003/3,
 - CE marking **CE** 1433,
 - maximum operating pressure $P_{\max} = 2 \text{ MPa}$,
 - ambient temperature $-25^{\circ}\text{C} \leq T_a \leq +70^{\circ}\text{C}$
 - harmonised standards PN-EN 1515:2002 (U), PN-EN 12392:2002 (U),
PN-EN 10269:2002 (U)
 - other applied regulations Requirements of Office of Technical Inspection.
Pressure equipment
WUDT/UC/2003 (WUDT-UC-WO,
WUDT-UC-WO-O/00, WUDT-UC-WO-O/01)
3. Operating position Horizontal or vertical
4. Metrology parameters see Table 2
5. Conformity with other standards PN-EN 12261:2003 (U), PN-92/M-54832.3
PN-M-54832-1/A1: 1995, ZN-G-4005,

Table 1. Physical properties of most popular gases that may be measured with the CPT-01 Quantometers - density at 101,325 kPa, and at 20°C

Gas or gas mixture	Chemical symbol (formula)	Density ρ [kg/m ³]	Density related to air	Gas meter execution
argon	Ar	1,66	1,38	standard IIB
nitrogen	N ₂	1,16	0,97	standard IIB
butane	C ₄ H ₁₀	2,53	2,1	standard IIB
carbon dioxide	CO ₂	1,84	1,53	standard IIB
ethane	C ₂ H ₆	1,27	1,06	standard IIB
ethylene	C ₂ H ₄	1,17	0,98	standard IIB
natural gas	≈CH ₄	ok. 0,75	ok. 0,63	standard IIB
helium	He	0,17	0,14	standard IIB
methane	CH ₄	0,67	0,55	standard IIB
propane	C ₃ H ₈	1,87	1,56	standard IIB
carbon monoxide	CO	1,16	0,97	standard IIB
acetylene	C ₂ H ₂	1,09	0,91	special IIC
hydrogen	H ₂	0,084	0,07	special IIC
air	-	1,20	1	standard IIB

Basic metrological parameters of the CPT-01 Quantometers are shown in Table 2.

This information is not to be considered as a trade offer. Appropriate information may be obtained from authorised dealers or from the Marketing Department.

Pressure loss

Quantometers create a pressure loss in the installation. These values, for the CPT-01 Quantometers, for the density $\rho_0 = 1,2 \text{ kg/m}^3$, may be determined from the chart, Fig. 1.

At operating conditions the pressure drop Δp_{rz} [Pa] may be calculated from the following formula:

$$\Delta p_{rz} = \frac{\rho}{\rho_0} \frac{p_a + p}{p_a} \Delta p$$

where: ρ - gas density, Table 1 [kg/m³],

p_a - atmospheric pressure ($p_a \cong 101$ [kPa]),

p - pipeline pressure upstream the gas meter [kPa],

Δp - pressure loss at base conditions (Figure 1) [Pa].

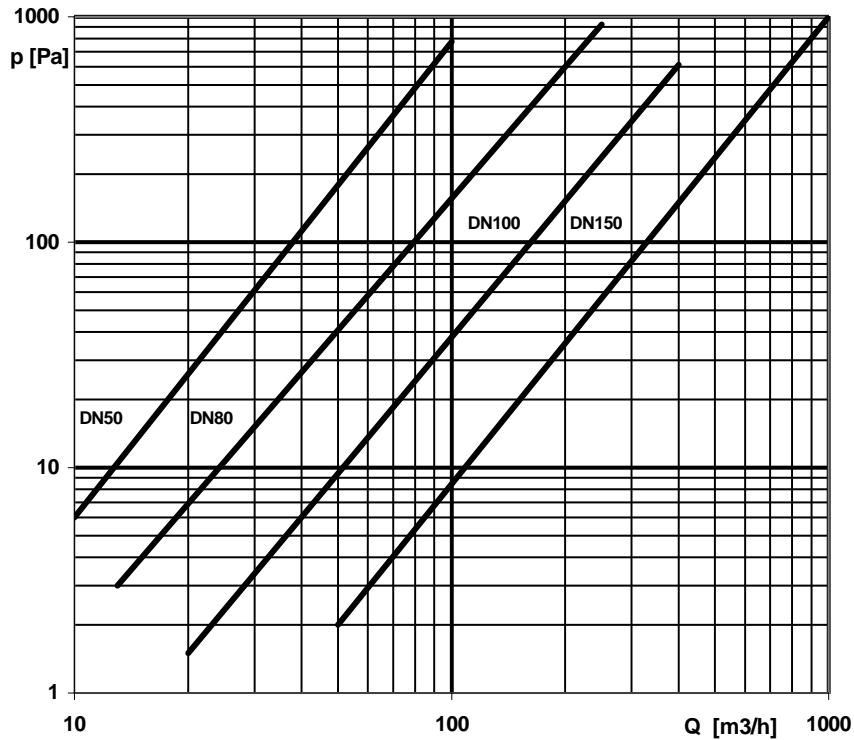

Fig.1. Pressure loss for CPT-02 Quantometers;
gas density $\rho_o = 1,2 \text{ kg/m}^3$

Table 2. Basic metrological parameters and digital codes of the CPT-01 Quantometers

Nominal diameter	Quantometer size	Maximum flow Q_{\max}	Minimum flow Q_{\min} for pressure range 1,6 MPa and turndown ratio:			Gas volume for one LF pulse	Digital code of the quantometer size
			1:10	1:20	1:30		
-	-	[m ³ /h]	[m ³ /h]	[m ³ /h]	[m ³ /h]	[m ³ /pulse]	-
DN 50	G 40	65	6	-	-	0,1	14....
	G 65	100	10	5	-		15....
DN 80	G 100	160	16	8	-	1	21....
	G 160	250	25	13	-		22....
	G 250	400	40	20	-		23....
DN 100	G 160	250	-	13	8	1	32....
	G 250	400	-	20	13		33....
	G 400	650	-	32	20		34....
DN 150	G 400	650	-	32	20	1	44....
	G 650	1000	-	50	32		45....
	G 1000	1600	-	80	50	10	41....

II. CONSTRUCTION AND OPERATION

The turbine quantometer operation is based on the proportionality of the rotational speed of the turbine wheel to the linear velocity thus to the flowing gas volume. Gas entering the gas meter (Fig. 2) is directed through the inlet flow straightener into the measurement assembly and causes the rotation of the turbine wheel. The wheel rotations are transmitted by means of gears and magnetic coupling into the index assembly. The index sums up the volume that has flown through the meter, and it is shown on the 8-digit counter. Proper performance of each CPT-01 Quantometer is maintained only in the range of Q_{\min} and Q_{\max} , as determined in Table 2.

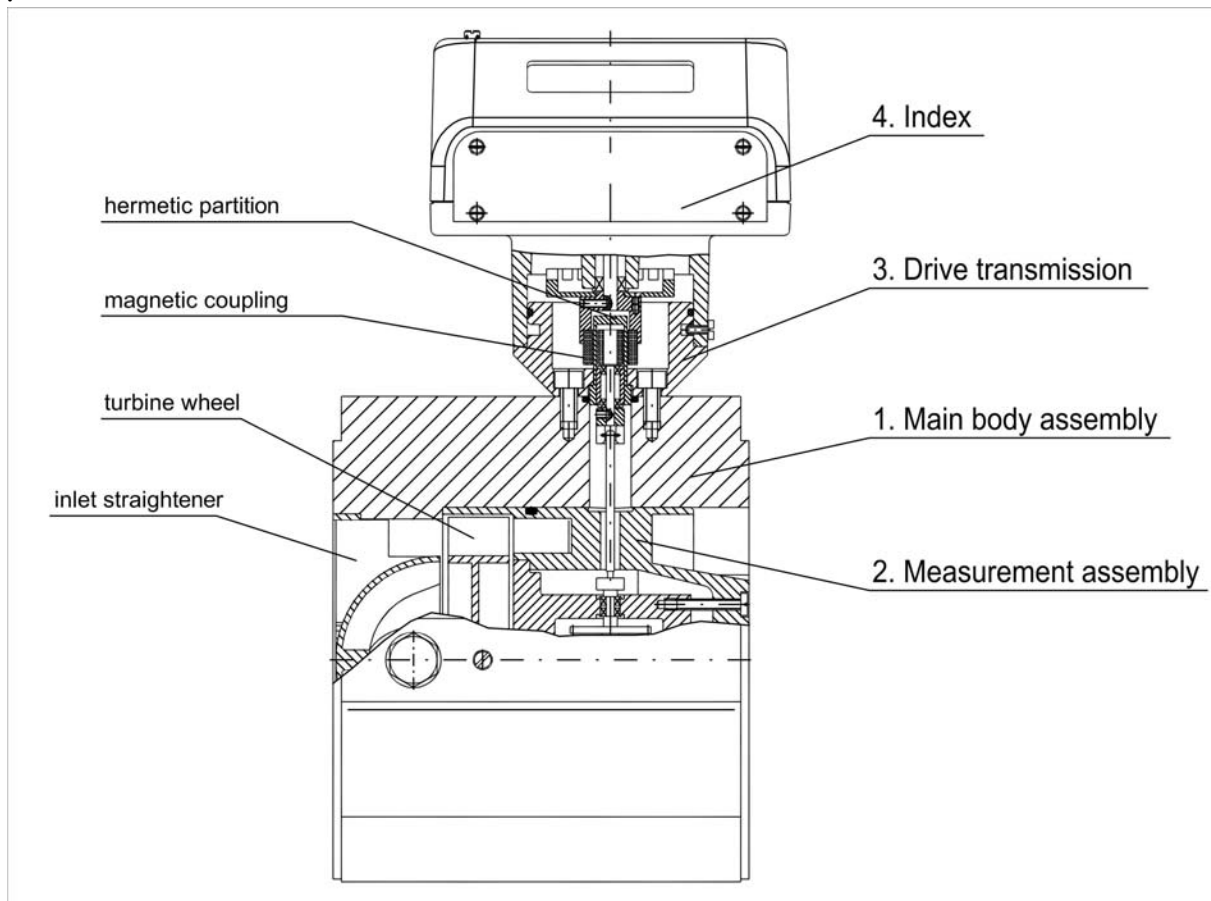

Fig.2. Cross section of the CPT-01 Quantometer

The CPT-01 Quantometer (Fig. 2) consists of four main assemblies:

1. Main body assembly. The main body assembly consists of the main body made of extruded aluminium profile, inlet straightener and plugs for taps. The main body is equipped with the pressure measurement tap and the tap for installation of the HF inductive transmitter. The inlet straightener, placed upstream the turbine wheel, distributes evenly the gas flow and directs it onto the turbine wheel vanes.

2. Measurement assembly. It consists of the turbine wheel, the turbine wheel housing, the measurement assembly housing, shafts and gears. The turbine wheel is placed in the axis of the quantometer body and is provided with high precision bearings. The transmission gear (worm gear and cylindrical gear) decreases the rotational velocity and transfers it to the magnetic coupling..

3. Drive transmission assembly. It is installed in the quantometer body. It consists of the mount with the hermetic, gas tight partition and the magnetic coupling. The driving part of the magnetic coupling is placed inside the quantometer and is connected with the turbine assembly by means of an articulated shaft. The driven part of the magnetic coupling is placed outside the partition and is connected with the index.

4. Index assembly. Consecutive reduction of the rotational speed is performed there (through the worm gear and cylindrical gear) in order to drive the mechanical totalizer, and inductors of low frequency pulse transmitters. The assembly contains also sockets for electric LF and HF output signals.

III. INDEX AND MEASUREMENT OUTPUTS

The reading assemblies of the CPT-01 Quantometer consist of a mechanical index with incorporated electric signal outputs, a pressure tap and a tap for installation of an external HF pulse transmitter (from the turbine wheel). These outputs enable the control of the instrument operation and connections of external devices. Location of measurement outputs on the quantometer is shown in the Fig. 3.

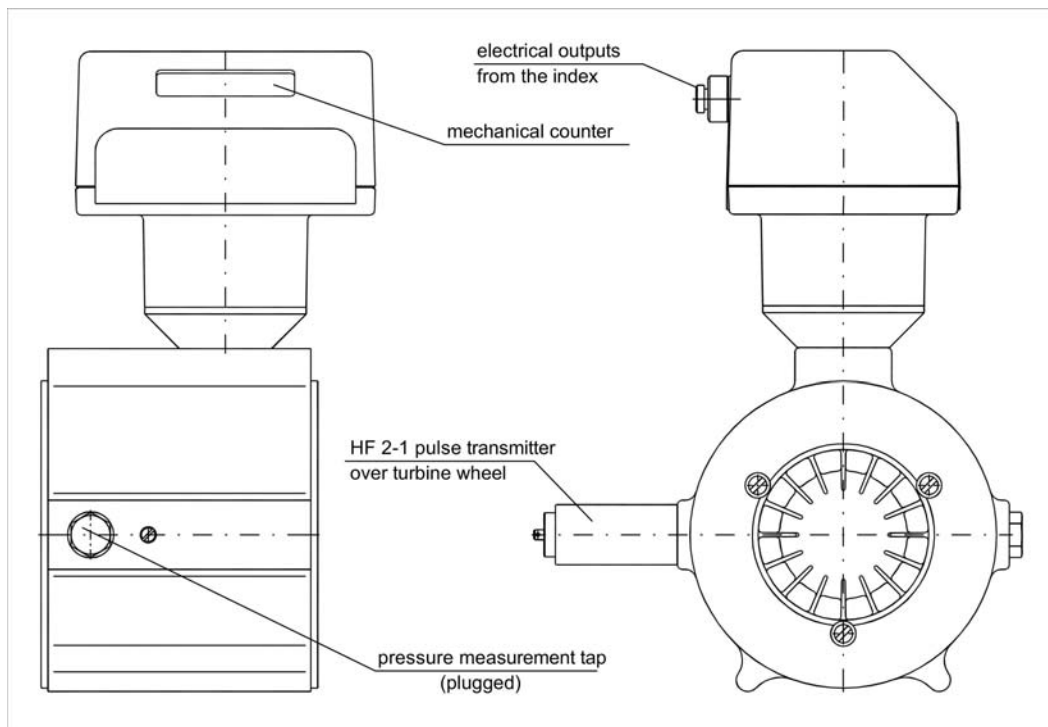

Fig.3. Location of the measurement outputs on the CPT-01 Quantometer

Mechanical index is located inside the index unit and is visible through the polycarbonate sight glass. It enables direct reading of the gas volume flowing through the meter at operating conditions, i.e. at actual pressure and temperature. The index unit may be rotated by 345° against its axis what enables reading of the index from any direction.

Electrical outputs from the index. There are two types of electric signal outputs: LF - low frequency and HF - high frequency. The index may be equipped with maximum two sockets and six pulse transmitters:

- two proximity inductive high frequency pulse transmitters HF,
- two gap inductive low frequency transmitters LFI,
- two reed contact low frequency transmitters LFK.

The LFK reed contact transmitters are designed for the cooperation with the battery volume corrector that is located in the vicinity of the gas meter (up to 2 m). The inductive transmitters, LFI and HF, may send electric signals for bigger distances (up to 200 m, depending on conditions). Because of higher current consumption they may cooperate only with power supplied volume correctors. Gas volume that corresponds to one pulse of the LF transmitter is given in Table 2.

Number of HF pulses for one m³ of gas is determined individually for each gas meter, and is indicated in the name plate.

A dash placed in the nameplate instead of number of pulses, or lack of description, indicates that an appropriate pulse transmitter has not been installed.

All pulse transmitters installed in the index head are connected to contacts of „Tuchel” C091 31N006 100 2 sockets. The sockets are located on the rear side of the index head. These sockets are to be used for connection of 6-pin plugs “Tuchel” C091 31H006 100 2. The “Tuchel” connection applied in the CPT-01 Quantometers are IP67. Possible connections of transmitters with appropriate electric signal sockets are given in Table 3.

Table 3. Possible connections of transmitters to electric output sockets.

	pin	polarity	LFK 1	LFI 1	HF 1	LFK 2	LFI 2	HF 2
Socket 1	1	-	S	O				
	4	+	S	O				
	2	-		P		O	O	O
	5	+		P		O	O	O
	3	-			P			
	6	+			P			
Socket 2	1	-		O		P		
	4	+		O		P		
	2	-		O		O	P	O
	5	+		O		O	P	O
	3	-			O			P
	6	+			O			P

S - connections for the standard execution gas meters

P - recommended connection for full version

O - optional connections

The CPT-01 Quantometer in standard execution is equipped with one reed contact transmitter LFK1.

According to the application conditions the CPT-01 Quantometers should be provided with transmitters of at least  II 2G EEx ib IIC T4 protection level. These conditions are met when the following pulse transmitters are used:

- HF type NJ0,8-5GM-N, manufactured by Pepperl+Fuchs GmbH  II 1G EEx ia IIC

T6.

- LFI type CLFI-02 manufactured by Common S.A. ⊕ II 2G EEx ia IIC T6.
- LFK type CLFK-02 manufactured by Common S.A. ⊕ II 2G EEx ia IIC T6

Permitted parameters of the intrinsically safe supply circuits (U_i, I_i, P_i), and maximum inductance and internal capacitance (L_i, C_i)

HF	LFI	LFK
$U_i = 16 \text{ V DC}$	$U_i = 15,5 \text{ V DC}$	$U_i = 15,5 \text{ V DC}$
$I_i = 25 \text{ mA}$	$I_i = 52 \text{ mA}$	$I_i = 52 \text{ mA}$
$P_i = 64 \text{ mW}$	$P_i = 169 \text{ mW}$	$P_i = 169 \text{ mW}$
$L_i = 50 \mu\text{H}$	$L_i \approx 40 \mu\text{H}$	$L_i \approx 0$
$C_i = 30 \text{ nF}$	$C_i = 28 \text{ nF}$	$C_i \approx 0$

Rated operation parameters of applied pulse transmitters:

	reed contact	CLFK-02:	
	rated voltage	$U_n = 5 \div 15,5 \text{ V DC},$	
	closed contact resistance	$R_z = 500\Omega \div 2 \text{ k}\Omega,$	
	open contact resistance	$R_o > 100 \text{ M}\Omega,$	
	maximum switching frequency	$f_p = 500 \text{ Hz}.$	
inductive		CLFI-02	NJ0,8-5GM-N
rated voltage		$U_n = 5 \div 15,5 \text{ V}$	$U_n = 5 \div 16 \text{ V},$
non active transmitter current		$I_L < 1,2 \text{ mA},$	$I_L < 1,2 \text{ mA},$
active transmitter current		$I_H > 2,1 \text{ mA},$	$I_H > 2,1 \text{ mA},$
load resistance		$R_n \leq 1 \text{ k}\Omega,$	$R_n \leq 1 \text{ k}\Omega,$
maximum switching frequency		$f_p = 200 \text{ Hz},$	$f_p = 5 \text{ kHz}.$

Depending on the transmitter state, (active or non active), a voltage drop on the 1 k Ω resistor occurs. For the above mentioned transmitter current values (according to PN EN 60947-5-6:2002) the input voltage values may be as follows:

- non active state $U_L < 1,2 \text{ V},$
- active state $U_H > 2,1 \text{ V}.$

Electrical outputs from HF transmitter installed in the CPT-01 Quantometer body

The high frequency transmitter may be installed in the quantometer body, over the turbine wheel. The turbine wheel is the modulating element of the HF transmitter magnetic field.

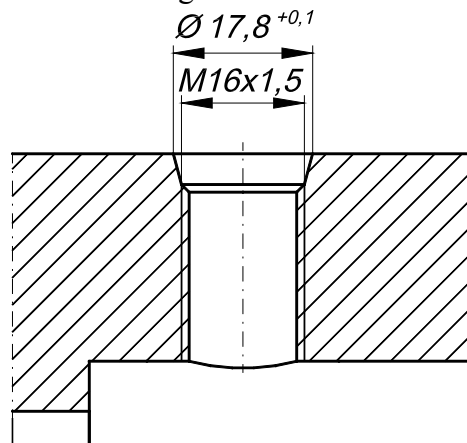

Fig.4. Dimensions of the HF transmitter tap in the quantometer body.

The pulse transmitter is installed in the tap shown in Fig.3. The tap is provided with M16 x 1,5 thread.

INSTALLATION OF THE HF TRANSMITTER IN THE GAS METER BODY REQUIRES CARE.

ZENER BARRIERS SHOULD BE USED.

THEREFORE IT MAY ONLY BE PERFORMED BY THE MANUFACTURER OR BY THE AUTHORISED REPRESENTATIVE.

The protection type of the transmitters should be at least $\text{Ex II 2G EEx ib IIC T5}$. These conditions are met by the following transmitters:

- HF type CHF1-02, manufactured by Common S.A. $\text{Ex II 2G EEx ia IIC T6}$
- HF type NJ1,5-10GM-N-Y07451, manufactured by Pepperl+Fuchs GmbH, $\text{Ex II 1G EEx ia IIC T6}$

Permissible supply parameters of the above mentioned transmitters from intrinsically safe circuits, maximum inductance and internal capacitance of the transmitters are as follows:

- CHF1-02 $U_i = 15,5 \text{ V}$, $I_i = 52 \text{ mA}$, $P_i = 169 \text{ mW}$, $L_i \approx 40 \mu\text{H}$, $C_i = 28 \text{ nF}$.
- NJ1,5-10GM-N-Y07451 $U_i = 16 \text{ V}$, $I_i = 25 \text{ mA}$, $P_i = 64 \text{ mW}$, $L_i = 50 \mu\text{H}$, $C_i = 20 \text{ nF}$.

The application conditions and supply parameters are marked on the transmitter housing.

The transmitters are equipped with 4-pin plugs „Tuchel” C091 31W004 100 2. The connecting cables should be provided with sockets „Tuchel” C091 31D004 100 2. The transmitter is connected to pins „3” and „4” of the plug. The sketch of the transmitter connection with the measurement circuit is show in Fig. 5.

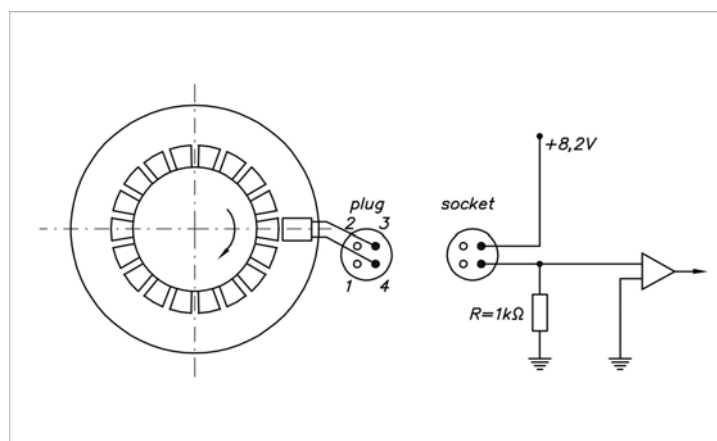

Fig.5. HF pulse transmitter connection sketch

The number of HF pulses per one m^3 of gas is determined individually for each gas meter and is indicated in the nameplate (Fig. 8) located on top of the index head..

A dash placed in the name plate instead of number of pulses, or lack of description, in-

dicates that an appropriate pulse transmitter has not been installed

The HF output is especially useful in order to control the changes of the gas flow.

Pressure measurement outputs.

Pressure measurement output (pressure pulse tap) is located on the side of the main body (Fig. 3). The tap may be provided either with M12x1,5 thread (Fig. 6) or NPT 1/4 thread (Fig. 7). The thread type is marked on the body. The pressure tap is used for connecting the pressure transmitters directly, or indirectly by means of a three-way valve.

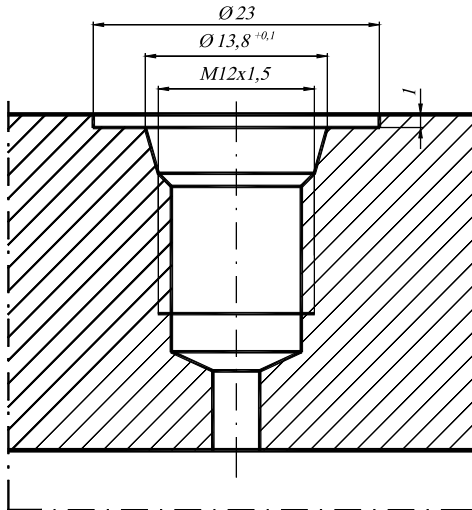

Fig. 6. M12x1,5 pressure measurement tap.

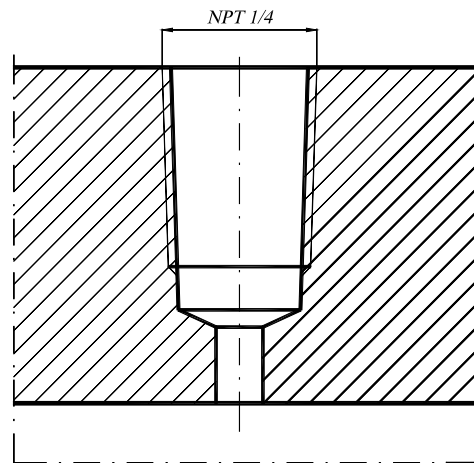

Fig 7. NPT 1/4 pressure measurement tap

IV. MARKING AND CALIBRATION OF THE QUANTOMETERS

Basic specification of the gas meter, serial number and production year is shown in the nameplates (Fig. 8 and Fig. 9). The plates are fixed to the index housing by means of screws. Two first digits of the serial number indicate the gas meter size code, according to Table 2. Information marks showing the flow direction, as well as pressure taps, are placed on the main body (Fig. 10).

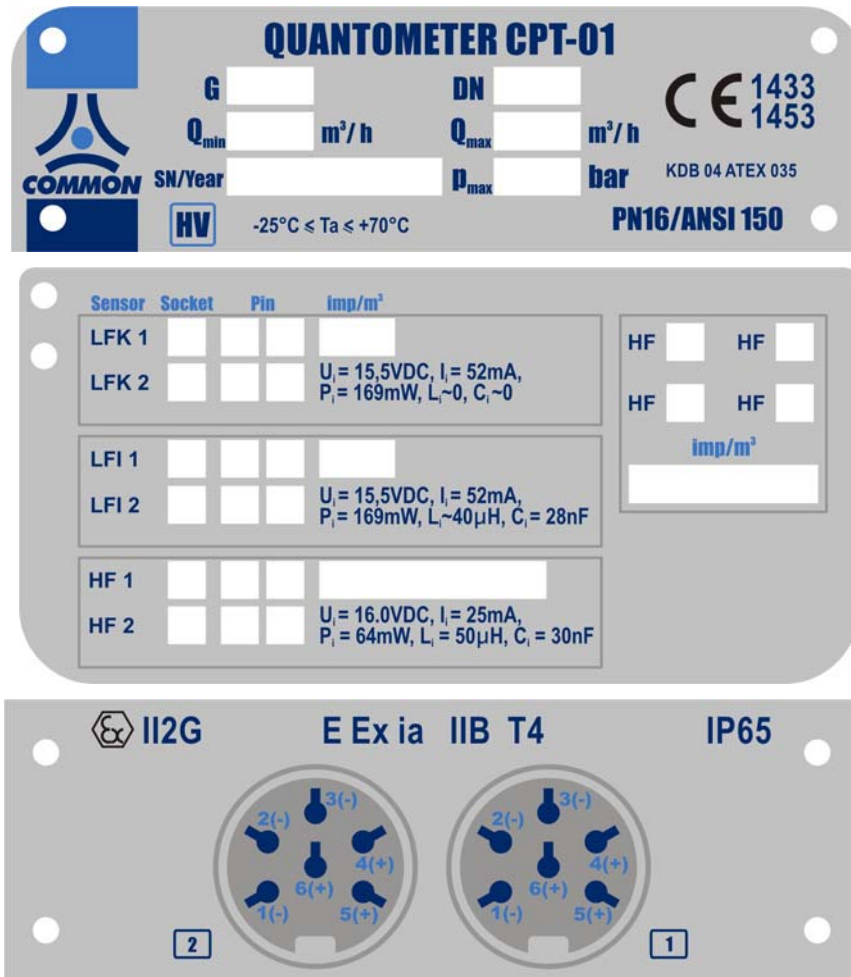

Fig. 8. Standard execution nameplates

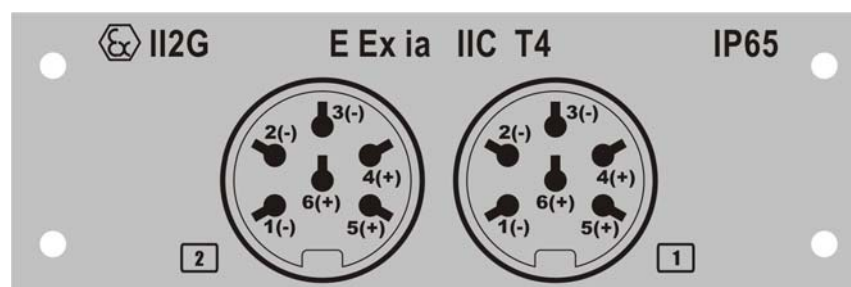

Fig. 9. Special execution nameplate



Fig.10. Information marks - flow direction and pressure output

Each quantometer is calibrated in the manufacturer's laboratory or other recognized laboratory. The calibration certificate is delivered with the quantometer. Connections that are not being dismantled during the quantometer installation are protected with factory seals or with a recognized laboratory seals (Nos 1, 2, 3, 4, 6, 8 and 9, Fig. 11).

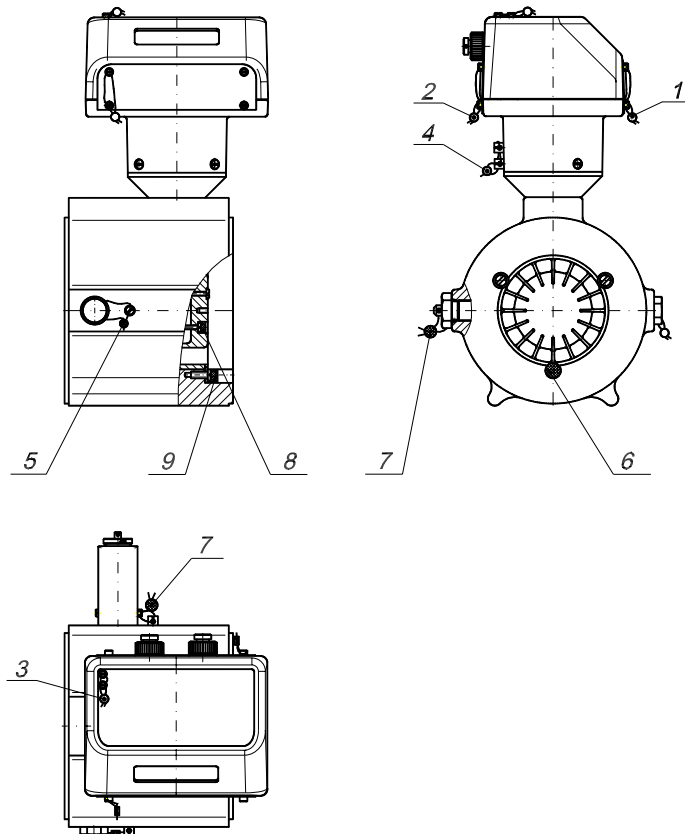

Fig.11. Location of seals on the CPT-01 quantometers

Protective seals installed on the pressure sensor tapping (No 5) and on the HF transmitter (No 7) are marked by the manufacturer, by the gas distributing company or by the authorized installer. Additionally the protective seals should be installed on unused electric signal output caps, and, if necessary, on the provided three way valve.

If the seals are damaged the guarantee may become invalid.

V. PACKAGING, TRANSPORTATION AND STORAGE

The gas meter is delivered in a factory packaging which secures the instrument during transportation and storage. The packaging consists of reinforced cardboard box with shaped styrofoam inserts. Appropriate information on the package content, as well as limitations on loading / unloading, is placed on the package.. The boxes are provided with special openings in order to facilitate handling of the quantometers. Quantometers returned for repairs or recalibration, should be delivered to the factory in their original packaging or other that provide at least the same protection during transportation as the original ones.

Each quantometer manufactured by COMMON S.A. is provided with the following accessories:

- 6-pin plug “Tuchel” C091 31H006 100 2 that may be used for connecting a volume corrector or a data logger low frequency electric output (if the volume corrector or data logger is not delivered as a set with the quantometer);
- 4-pin socket “Tuchel” C091 31D004 100 2, if the gas meter is equipped with HF transmitter installed in the body;
- Operating instruction

THE TURBINE QUANTOMETER IS A PRECISE MEASURING INSTRUMENT AND SHOULD BE HANDLED WITH UTMOST CARE..

Following recommendations should be observed during transportation and storage:

1. The quantometers during transportation should be protected against falls, shocks, or strong vibrations (e.g. due to handling on improper trolleys)
2. Lifting the quantometers by means of the index housing is not allowed..
3. Factory installed covers or seals on the gas meters openings should be removed just before the meter installation..
4. The quantometers during storing should be protected against direct atmospheric influence, and against humidity.
5. Take care not to damage the protective seals installed on the quantometer.

VI. INSTALLATION AND START-UP

Prior to the installation of the quantometer check whether it has been selected properly, in accordance with the operating parameters of the system. In particular, attention should be paid to the following information contained in the nameplate:

- maximum operating pressure [MPa], marked p_{\max} ,
- maximum real flow [m^3/h], marked Q_{\max} .
- .

It is permitted to operate the quantometer with flow bigger by 25% than the designed maximum flow within maximum 30 minutes.

The quantometers should not be installed in the lowest position of the installation as it is possible that condensate and other impurities may collect there.

The quantometers should be installed in closed compartments or under appropriate shields. It is not permitted to expose the gas meters to rain or snow falls, or to pollution with other substances (e.g. dust).

The quantometer should be installed in piping of the appropriate nominal diameter. Proper alignment of the meter and pipe flanges should be secured. It is recommended to install appropriate upstream and downstream pipe sections. The quantometers are to be installed between flanges PN16 or PN20 (ANSI 150).

When designing the installation follow the dimensions given in Table 3, and Fig. 12.

Table 3. Basic dimensions and weight of the CPT-01 quantometers

DN	A	B	C	D	E	F	G	H	Weight
mm	mm	mm	mm	mm	mm	mm	mm	mm	kg
50	100	65	18	32	140	65	199	252	3,6
80	120	80	21	38	150	77	211	278	5,3
100	150	100	29	53	165	91	225	305	7,4
150	180	127	50	76	190	116	243	351	11,6

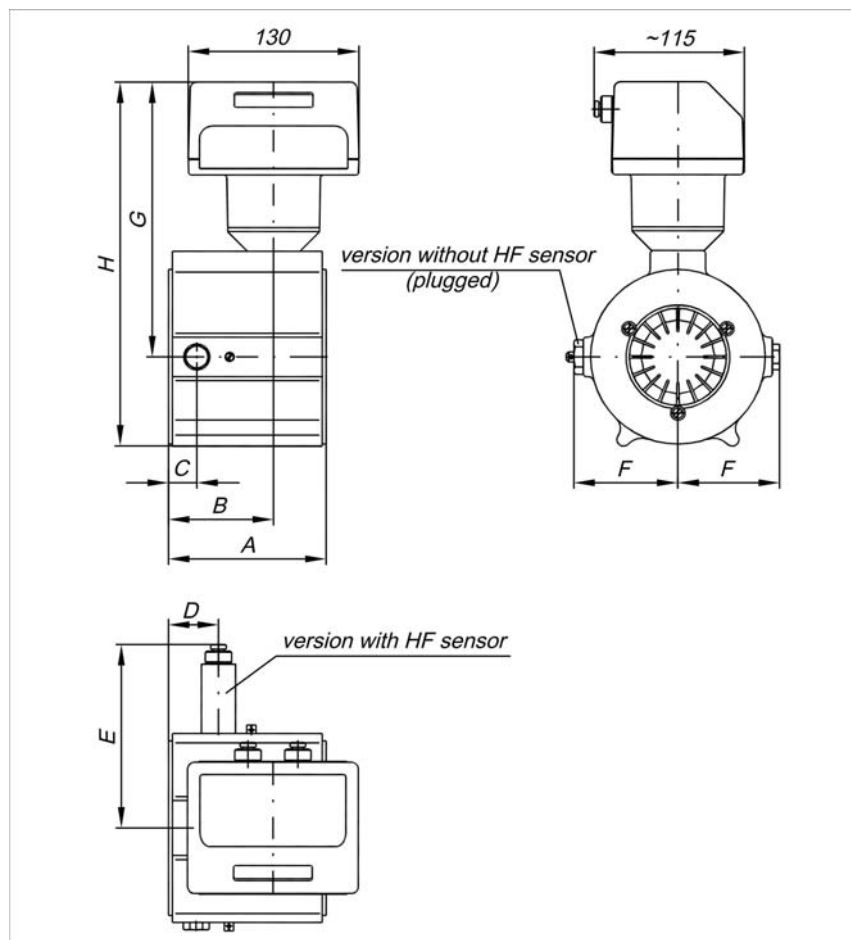

Fig.12. Basic dimensions of the CPT-01 Quantometers

Impurities contained in gas and in the piping may cause damages to the measuring assembly and decrease the measurement accuracy. Therefore it is recommended to install the 10 µm filter upstream the quantometer (especially in case of heavy polluted gases). Besides, prior to the installation, it is recommended to clean the upstream piping, and to provide a Top Hat Filter (cone sieve) before the meter. The cone sieve may be removed after 1 – 2 months of operation. If the cone sieve is not removed than it is necessary to maintain it regularly and control the pressure drop. If the cone sieve is clogged it may get damaged by the gas pressure, and the debris may seriously damage the quantometer .

THE MANUFACTURER IS NOT LIABLE FOR ANY DAMAGES TO THE QUANTOMETER DUE TO IMPROPER FILTRATION OF THE FLOWING GAS

The user of the gas meter should pay special attention to some risk related to gas flow changes. If for a longer time, after commissioning, the flow in the piping was relatively low the impurities (e.g. weld spatters) remain upstream the gas meter. When the flow increases the flowing gas may sweep away these impurities and in consequence the gas meter may get damaged. Due to that the cone sieves are very practical solution when the new installation is reaching its designed output. Nevertheless, the user should protect the gas meter against mechanical damages.

Prior to the installation of the gas meter it is necessary to check whether it is oriented properly, i.e. whether the arrow located on the body indicates the proper flow direction.

The quantometers are to be fixed in the piping by means of stud bolts, according to the following standards: PN-EN ISO 898-1:2001, PN-EN ISO 3506-1:2000, PN-ISO 888:1996. For standard flanges flat gaskets may be used (acc. to PN-EN 1514-1:2001 or PN-EN 12560-1:2002)

Unused electric output sockets must be closed with factory supplied caps and seals in order to protect them against corrosion and pollution.

START-UP

In order to start up the quantometer properly the following recommendations should be observed (typical installation with the by-pass, Fig.13):

1. The quantometer is installed with the valves 1, 2, 5 closed, and the by-pass valve 4 open. The vent valve 3 remains open after venting the installation.
2. Having tightened the bolts remove the air from the installation by opening the valve 5. This must be done in accordance with appropriate local regulations. The valve 3 remains open.
3. Having removed the air from the installation close valve 3 and pressurize the installation. Observe that the pressure increase is no greater than 30 ± 10 kPa/s.
4. When the index does not indicate any flow (it means that the pressure is equal in the installation), close the valve 5.
5. First, open the valve 1 and next the valve 2.
6. Having fully opened the valve 2, the by-pass valve 4 is to be closed.

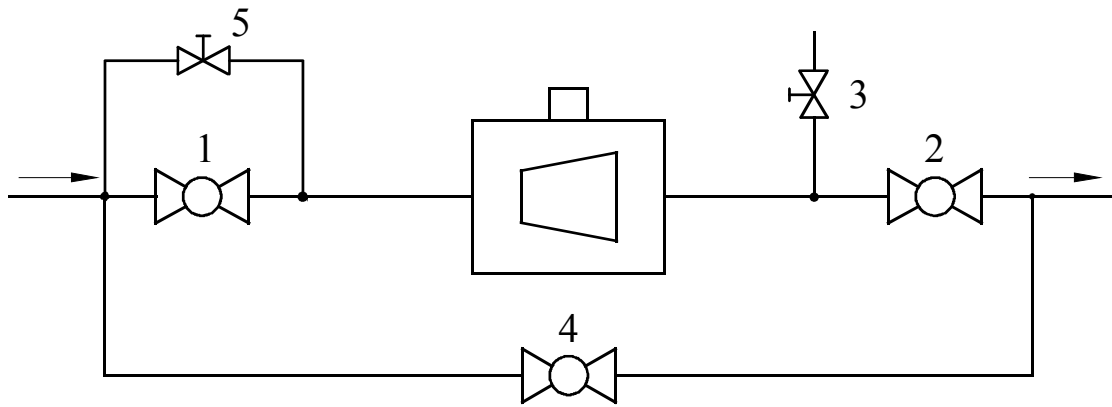

Fig. 13. Diagram of the measuring system with the by-pass valve When removing the gas meter from the installation, proceed opposite, i.e.:

1. First, open the by-pass valve 4,
2. Consecutively, close the valve 2, and next the valve 1
3. Release the pressure from the measurement installation by means of the vent valve 3; pressure decrease should be not more than 30 ± 10 kPa/s.

In other cases the procedure should be similar, i.e. open and close the gas flow through the gas meter very slowly. Sudden increase of flow caused by abrupt opening of valves may bring about damages to the measurement turbine due to large pressure difference upstream and downstream the meter.

If during the usage of the gas meter overchargings may occur (i.e. Q_{\max} may be overcome by more than 25 %), then it is recommended to install orifices. The orifice should be installed downstream the gas meter at the distance of 5 to 10 nominal pipe diameters. The orifice plate size is determined individually, depending on the nominal pipe diameter, flow, pressure and temperature of the gas. On customer's demand COMMON S.A. may provide appropriate orifices.

After installation of the quantometer check whether indications of the index are proper. Each drum of the index should rotate freely, and after one full turn it should move the next left drum by $1/10^{\text{th}}$ of its rotation.

VII. MAINTENANCE, FAULTS, REPAIRS

The CPT-01 Quantometers need no maintenance. The bearings used in the construction are self lubricating, therefore the only maintenance activity is cleaning the meters from dust and other impurities, especially from the index sight glass. Use a cloth soaked with water and soap solution. It is not allowed to use thinners or other chemical agents.

If during operation of the gas meter any abnormality occur (e.g. uneven run, stoppage of index, higher noise level, rattling) the quantometer should be removed from the installation and sent for repair.

**REPAIRS OF THE QUANTOMETERS MAY BE PERFORMED ONLY BY
THE MANUFACTURER OR BY AUTHORISED PERSONNEL.
IS NOT ALLOWED TO PERFORM REPAIRS BY THE USER!**

After repairs when calibrations leaden seals were removed it is necessary to recalibrate the quantometer.

VIII. AUXILIARY EQUIPMENT

In order to convert gas volume from operating into base conditions it is often required (or recommended) to use electronic volume converters. Common S.A. is also the manufacturer of such devices, e.g. volume correctors CMK-02 and data loggers CRI-02. On requests COMMON S.A. may deliver these devices. Example of such installation is shown in Fig.14.

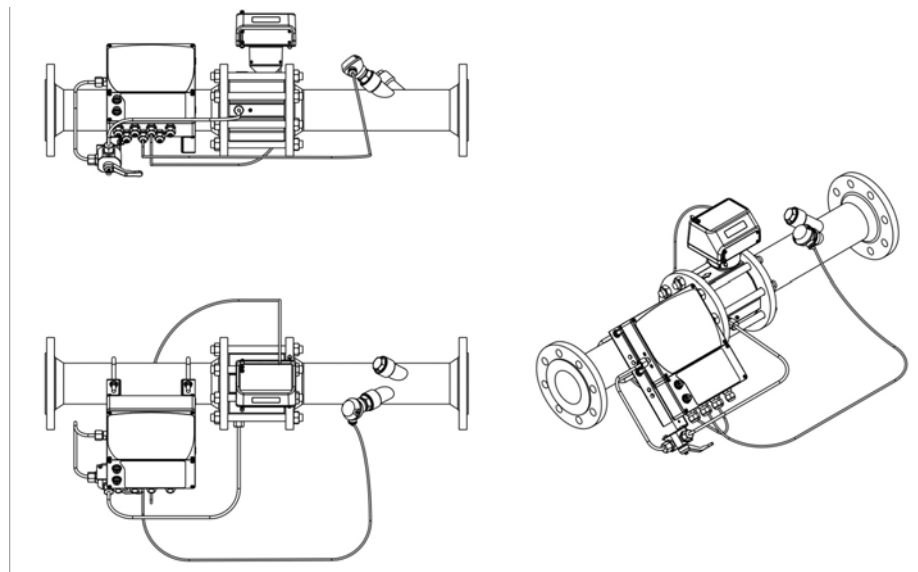

Fig 14. Assembly of the CPT-01 Quantometer and the CMK-02 volume corrector (the volume corrector installed on the pipe)

The volume corrector needs three input signals:

- flow (from the low frequency or high frequency pulse transmitter),
- pressure,
- temperature.

The pressure pulse is taken from the pressure tap. It is recommended to take the pressure pulses by means of the CKMT three way valve (Fig. 15) that enables to cut off the pressure

sensor, and in consequence to disassemble and inspect this sensor. There is no need to stop the gas flow through the quantometer. The three way valve handle may be provided with a seal in order to protect it against unauthorized handling. The temperature signal is taken from a sensor installed in a temperature pocket downstream the quantometer (see Fig. 14).



Fig. 15. CKMT three way valve

It should be kept in mind that all connections of additional equipment to the quantometer cause that the installation seals get damaged. Therefore such works may be performed by the representative of the gas supply company or by the manufacturer. Unused electric output sockets must be closed by means of factory caps in order to protect them against corrosion and dirt.

Notice:

Technical specification and construction may change due to improvements. This publication serves as general information only, and all specifications are subject to confirmation by COMMON S.A.