

# Industrial Gas Meter G65

## Exact measurement and security



### Overview

The gas meter G65 is designed for measurement of gas supplied to industrial plants where maximum consumption of gas is equivalent to 100m<sup>3</sup>/h of air of density of 1,2 kg/m<sup>3</sup>.

The gas meters can be used for measurement of:

- Natural gas
- City gas
- Propane-butane gas

Gas meter in standard version is equipped with pulse magnet. Pulse transmitter (1 imp = 0,1m<sup>3</sup>) can be added at any time.



### Technical Data

Maximum flow rate:	Q <sub>max</sub> = 100 m <sup>3</sup> /h
Minimum flow rate:	Q <sub>min</sub> = 0,65 m <sup>3</sup> /h
Nominal flow rate:	Q <sub>n</sub> = 65 m <sup>3</sup> /h
Cyclic volume:	V = 65 dm <sup>3</sup>
Max. working pressure:	P <sub>max</sub> = 0,2 bar
Index max indication	99999,999 m <sup>3</sup>
Starting flow rate:	32 dm <sup>3</sup> /h
Weight:	90 kg

### Dimensions

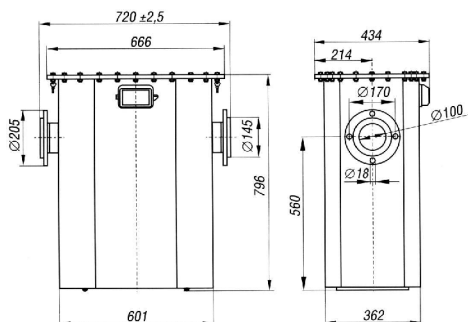

### Pressure loss curves

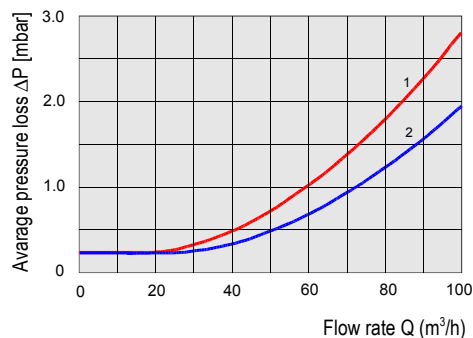

- 1 – air  
2 – natural gas

### Typical error curves

