

MULTICAL® 601

Precise measuring of heat and cooling up to 3000 m³/h

Pt100, 2-wire
Pt500, 2- and 4-wire

Available with ULTRAFLOW® from qp 0.6 to 1000 m³/h

24 VAC, 230 VAC or 10 years' battery supply

Data logging for 460 days, 36 months and 15 years

Leak detection of heat and tap water

Complies with EN 1434:2004 Class C and MID

Room for two extra plug-in modules

- Top module: Clock back-up, CE+CV outputs, PQ-limiter
- Base module: M-Bus, RF/Router, LonWork 0/4...20 mA outputs and pulse inputs for electricity and water meters



TS 27.01
155
EN 1434

PTB

22.52
05.04

MID-2004/22/EC

CE M07 0200

Application

MULTICAL® 601 is used for measurement of both heat and cooling in all water based plants with flow temperatures from 2°C to 180°C and with all flow meter sizes between qp 0.6 m³/h and qp 3000 m³/h.

The meter is simple to install, read and verify. Furthermore, MULTICAL® 601 contributes to keeping the annual operating costs at a minimum with its unique combination of high measuring accuracy and long life-time.

If MULTICAL® 601 is connected to flow meters installed in both flow and return pipes, the meter can monitor leaks and burst in the heating/cooling system. Furthermore, leakages in the tap water system can be monitored by means of pulses if a water meter is connected.

MULTICAL® 601 receives volume pulses from the connected flow meters and calculates the energy for every predetermined water volume. The energy calculation includes temperature measurements in flow and return as well as correction for density and heat content according to EN 1434.

MULTICAL® 601 can be supplied by either battery, 230 VAC or 24 VAC.

MULTICAL® 601 can be extended by two internal modules – a top module with clock backup, pulse outputs or valve control and a base module with M-Bus, radio, LonWorks or 0/4...20 mA outputs. Furthermore, the base module includes two extra pulse inputs for connection of water and electricity meters, making it possible to collect all consumption data with one single automatic data reading.



Kamstrup

Kamstrup A/S
Industrivej 28, Stilling
DK-8660 Skanderborg
TEL: +45 89 93 10 00
FAX: +45 89 93 10 01
info@kamstrup.com
www.kamstrup.com

Calculator functions

Energy calculation

MULTICAL® 601 calculates energy based on the formula in EN 1434-1:2004, in which the international temperature scale from 1990 (ITS-90) and the pressure definition of 16 bar is used.

The energy calculation can in a simplified way be expressed as:

$$\text{Energy} = V \times \Delta\theta \times k$$

V is the supplied water volume

$\Delta\theta$ is the temperature difference measured

k is the thermal coefficient of water

The calculator always calculates energy in [Wh], and then it is converted into the selected measuring unit.



E [Wh] =	$V \times \Delta\theta \times k \times 1000$
E [kWh] =	$E [\text{Wh}] / 1.000$
E [MWh] =	$E [\text{Wh}] / 1.000.000$
E [GJ] =	$E [\text{Wh}] / 277.780$
E [Gcal] =	$E [\text{Wh}] / 1.163.100$

Application types

MULTICAL® 601 operates with 9 different energy formulas, E1...E9, that are all calculated in parallel in connection with each integration no matter how the meter is configured.

The energy types E1 to E9 are calculated as follows:

$$E1 = V1(T1 - T2) \quad \text{Heat energy (V1 in flow or return)}$$

$$E2 = V2(T1 - T2) \quad \text{Heat energy (V2 in return)}$$

$$E3 = V1(T2 - T1) \quad \text{Cooling energy (V1 in flow or return)}$$

$$E4 = V1(T1 - T3) \quad \text{Forward energy}$$

$$E5 = V2(T2 - T3) \quad \text{Return energy or tapping from return}$$

$$E6 = V2(T3 - T4) \quad \text{Tap water energy, separate}$$

$$E7 = V2(T1 - T3) \quad \text{Tap water energy, flow pipe}$$

$$E8 = m^3 \cdot T1 \quad \text{(Flow pipe)}$$

$$E9 = m^3 \cdot T2 \quad \text{(Return pipe)}$$

This renders MULTICAL® 601 capable of calculating the heat and cooling energy of most applications, both closed and open systems.

All energy types are data logged and can be displayed independent of configuration.

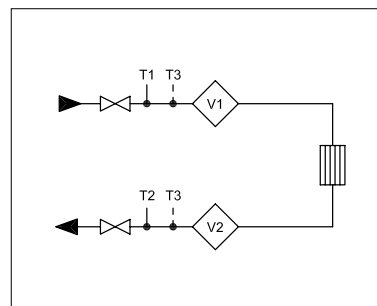

Example 1:
Closed thermal system
with 1 or 2 flow sensors

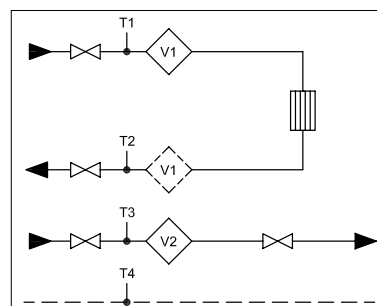

Example 2:
Closed thermal system
with 2 flow sensors

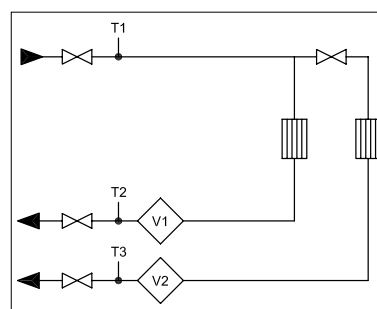

Example 3:
2 heat circuits with joint
flow

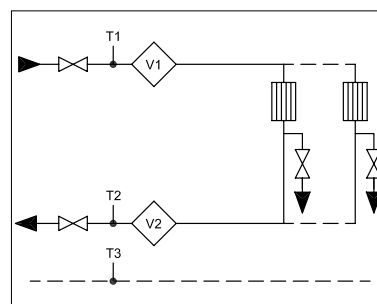

Example 4:
Open system with 2 flow
sensors

Calculator functions

Flow measurement

MULTICAL® 601 calculates current water flow according to two different principles depending on the connected flow sensor type:

- The flow indication of electronic flow meters is updated every 10 seconds.
- The flow indication of mechanical flow meters, typically with reed contact, is calculated on the basis of periodic time measurement and is updated with each volume pulse.

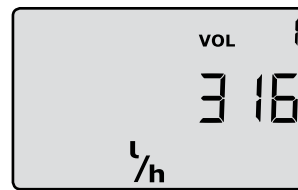

Power measurement

MULTICAL® 601 calculates current power on the basis of current water flow and the temperature difference measured in connection with the latest integration.

Current power is updated in the display simultaneously with the flow update.

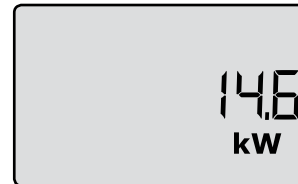

Min. and max. flow and power

MULTICAL® 601 registers minimum and maximum flow and power on a monthly as well as on a yearly basis. The registrations which appear from the display or can be read via data communication include max. and min. flow and power values, all with date indication.

All max. and min. values are calculated as largest and smallest average respectively of a number of current flow or power measurements. The average period used for all calculations is selected in the interval 1...1440 min.

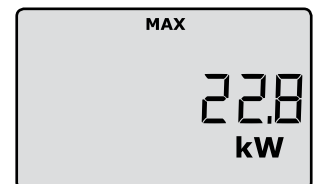
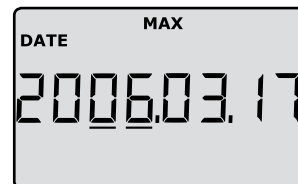

Temperature measurement

MULTICAL® 601 is available in different versions for either Pt100 or Pt500 sensors as well as in 2-wire and 4-wire versions.

The measuring circuit includes a high resolution analog/digital converter with a temperature range of 0,00°C...185,00°C.

In addition to current temperatures for the energy calculation average temperatures on a yearly and monthly basis can also be displayed.

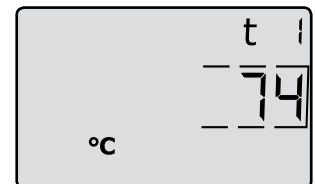
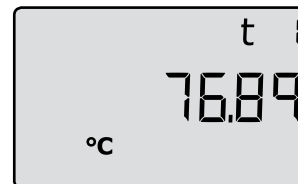

Display functions

MULTICAL® 601 is equipped with a clear LC display including 8 digits, units of measurement and information panel. In connection with energy and volume readings 7 digits and the units of measurement to match are used, whereas 8 digits are used when e.g. meter number is read.

As a starting point the display shows accumulated energy. When the push buttons are activated the display reacts immediately by calling other readings. The display automatically returns to accumulated energy reading 4 minutes after the latest activation of the push buttons.

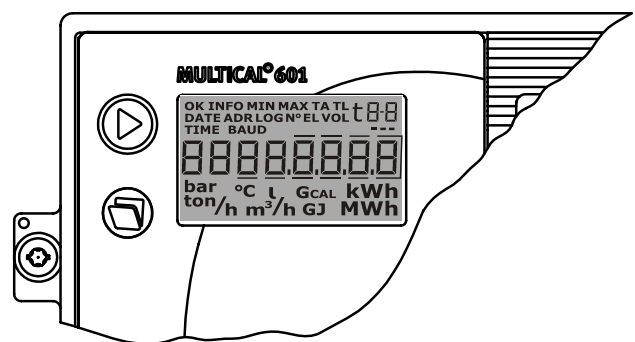

The upper push button is used to switch between the primary readings. The consumers typically use the first primary readings in connection with self-reading for billing purposes.

The lower push button is used to show secondary information on the selected primary reading.

Calculator functions

Info codes

MULTICAL® constantly monitors a number of important functions, e.g. power supply, temperature sensors and leakage alarms. Should a serious error occur in the measuring system or in the installation, a flashing “info” will appear in the display whilst the error exists. The “Info” panel will automatically disappear when the error has been corrected.

An Info Event Logger indicates how many times the info code has been changed.

The info logger stores the latest 50 changes, of which 36 can be displayed.

Info code	Description
00000	No irregularities
00001	Supply voltage connected after cut off
00004	T2 sensor outside range, short-circuited or cut off
00008	T1 sensor outside range, short-circuited or cut off
00032	T3 sensor outside range, short-circuited or cut off
00064	Cold-water leakage
00256	District heating leak
00512	District heating burst

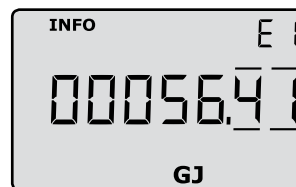

Data loggers

MULTICAL® 601 contains a permanent memory (EEPROM), where the results of a number of various data loggers are stored. The meter contains the following data loggers which can be read on the display or via serial data:

Data logging interval	Data logging depth	Logged value
Yearly logger	15 years	Counter (as seen on the display)
Monthly logger	36 months	Counter (as seen on the display)
Daily logger	460 days	Consumption (increase)/day
Hourly logger (option)	1392 hours	Consumption (increase)/hour
Info logger	50 events	Info code and date

Leak surveillance

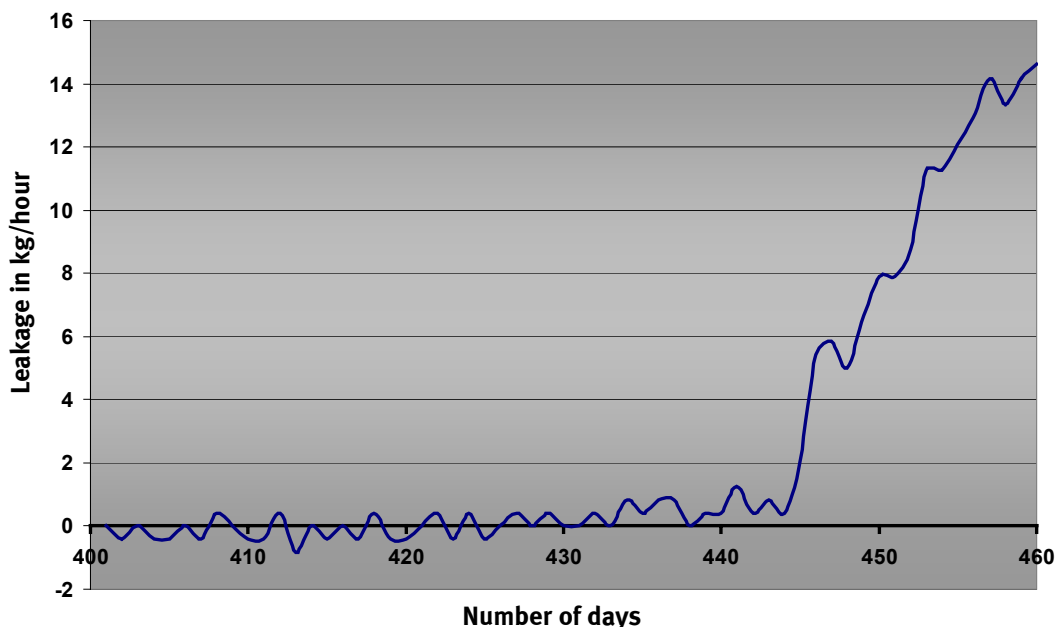

District heating systems

The leak surveillance system is primarily intended for direct connected district heating installations. The surveillance system consists of two water meters based on the ultrasonic principle, placed in flow and return pipe respectively, and of temperature sensors in both pipes. MULTICAL® 601 monitors the mass difference that may appear between flow and return pipe.

Cold-water systems

The pulse signal from the cold-water meter of the house can be connected to MULTICAL® 601. In this way it can monitor the cold-water consumption. A flushing toilet cistern, leaky heating coils in the water tanks or other leaks will cause that impulses from the cold-water meter are received 24 hours a day.

Calculator functions

Pulse inputs VA and VB

MULTICAL® 601 has two extra pulse inputs, VA and VB, to collect and accumulate pulses remotely, e.g from cold-water meters and electricity meters. The pulse inputs are physically placed on the "base modules".

The pulse inputs VA and VB function independently of the other inputs/outputs.

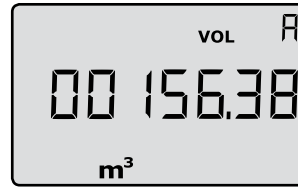

Voltage supply

MULTICAL® 601 is available with battery supply, 230 VAC mains module, or 24 VAC mains module. The supply modules are exchangeable without breaking the verification seal.

Plug-in modules

Plug-in modules can be added to MULTICAL® 601 both in the calculator top (top modules) and in the base unit (base modules), in this way the meter can adapt to various applications and data reading methods.

Programming and verification

METER TOOL for MULTICAL® 601 is a Windows® -based software which includes all facilities for calculator programming. If the software is used together with VERIFICATION EQUIPMENT for MULTICAL® 601, the calculator can be tested and verified.

Tariff functions

MULTICAL® 601 has 2 extra registers TA2 and TA3 to accumulate energy parallelly to the main register based on a programmed tariff condition. No matter which tariff type you select the tariff registers will be displayed as TA2 and TA3.

The main register is always accumulated, irrespective of the selected tariff function, as it is considered the legal billing register. Tariff conditions TL2 and TL3 are monitored before each integration. If the tariff conditions are fulfilled, the consumed heat energy is accumulated in either TA2 or TA3, as well as the main register.

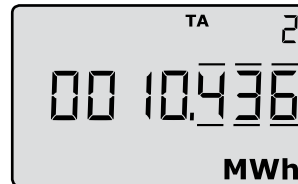

Approved meter data

Approval	PTB 22.52/05.04, PTB 22.55/05.01, TS 27.01/155	Flow sensor types	– ULTRAFLOW® – Electronic meters with active 24 V pulse output – Mechanical meters with electronic pick-up – Mechanical meters with reed switch
Standard	EN 1434:2004 and OIML R75:2002	Flow sensor sizes	– [kWh] qp 0.6 m ³ /h...qp 15 m ³ /h – [MWh] qp 0.6 m ³ /h...qp 1500 m ³ /h – [GJ] qp 0.6 m ³ /h...qp 3000 m ³ /h
EU-directives		EN 1434 designation	Environmental class A and C
– MID (Measuring Instruments Directive)		MID designation	
– LVD (Low Voltage Directive)		– Mechanical environment	Class M1
– EMC (Electromagnetic Compatibility Directive)		– Electromagnetic environment	Class E1 and E2
Temperature range	θ: 2°C...180°C		
Differential range	Δθ: 3K...170K		
Accuracy	$E_c \pm(0.5 + \Delta\theta_{\min}/\Delta\theta)\%$		
Temperature sensors			
– Type 67-A	Pt100 EN 60 751, 2-wire connection		
– Type 67-B+67-D	Pt500 EN 60 751, 4-wire connection		
– Type 67-C	Pt500 EN 60 751, 2-wire connection		

Electrical data

Calculator data

Typical accuracy	
– Calculator	$E_c \pm(0.15 + 2/\Delta\theta)\%$
– Sensor set	$E_T \pm(0.4 + 4/\Delta\theta)\%$
Display	LCD – 7 (8) digits with a digit height of 7.6 mm
Resolution	9999.999 – 99999.99 – 999999.9 – 9999999
Energy units	MWh – kWh – GJ – Gcal
Data logger (Eeprom)	
– Standard	460 days, 36 months, 15 years, 50 info codes
– Option	Data loggers with larger depth and hour interval
Clock/calendar	
– Standard	Clock, calendar, leap-year compensation, target date
– Option	Real time clock with battery back-up
Data communication	
– Standard	KMP protocol with CRC16 used for optical communication and for top and base modules.
– Option	MULTICAL® 66-CDE compatible data for base modules.
Power in temperature sensors	< 10 μW RMS
Supply voltage	3.6 VDC ± 5%
Battery	3.65 VDC, D-cell lithium

Closed circuit	< 35 μA excluding flow sensor
Replacement interval	
– Mounted on wall	10 years @ $t_{BAT} < 30^\circ\text{C}$
– Mounted on flow sensor	8 years @ $t_{BAT} < 40^\circ\text{C}$ The replacement interval is reduced when using data modules, frequent data communication or high am- bient temperature.
Mains supply	230 VAC +15/-30%, 50/60 Hz 24 VAC ±50%, 50/60 Hz
Insulation voltage	4 kV
Power supply	< 1W
Backup supply	Integral super-cap eliminates oper- ational stop-down due to short- term power cuts.
EMC data	Meets EN 1434 Class C (MID Class E2).
Temperature measurement	
Sensor inputs T1, T2, T3	
– Measuring range	0.00...185.00°C
Temperature T3, T4	
– Preset range	0.01...180.00°C
Max. cable lengths	
– Pt100, 2-wire	2 x 0.25 mm ² : 2.5 m 2 x 0.50 mm ² : 5 m
– Pt500, 2-wire	2 x 0.25 mm ² : 10 m 2 x 0.50 mm ² : 20 m
– Pt500, 4-wire	4 x 0.25 mm ² : 100 m

Electrical data

Flow measuring V1 and V2	ULTRAFLOW® V1: 9-10-11 and V2: 9-69-11	Reed switches V1: 10-11 and V2: 69-11	24 V active pulses V1: 10B-11B and V2: 69B-79B
EN 1434 pulse class	IC	IB	(IA)
Pulse input	680 kΩ pull-up to 3.6 V	680 kΩ pull-up to 3.6 V	12 mA at 24 V
Pulse ON	< 0.4 V for > 0.5 msec.	< 0.4 V for > 50 msec.	< 4 V for > 0.5 msec.
Pulse OFF	> 2.5 V for > 10 msec.	> 2.5 V for > 50 msec.	> 12 V for > 10 msec.
Pulse frequency	< 128 Hz	< 1 Hz	< 128 Hz
Integration frequency	< 1 Hz	< 1 Hz	< 1 Hz
Electrical isolation	No	No	2 kV
Max. cable length	10 m	25 m	100 m

Pulse inputs VA and VB VA: 65-66 og VB: 67-68	Water meter connection FF(VA) and GG(VB) = 01...40	Electricity meter connection FF(VA) and GG(VB) = 50...60
Pulse input	680 kΩ pull-up to 3.6 V	680 kΩ pull-up to 3.6 V
Pulse ON	< 0.4 V for > 0.1 sec.	< 0.4 V for > 0.1 sec.
Pulse OFF	> 2.5 V for > 0.1 sec.	> 2.5 V for > 0.1 sec.
Pulse frequency	< 1 Hz	< 3 Hz
Electrical isolation	No	No
Max. cable length	25 m	25 m

Pulse outputs CE and CV – via top module	
Type	Open collector (OB)
Pulse length	Optionally 32 msec. or 100 msec. for top module 67-04 (32 msec. for 67-06)
External voltage	5...30 VDC
Current	1...10 mA
Residual voltage	$U_{CE} \approx 1 \text{ V}$ at 10 mA
Electrical isolation	2 kV
Max. cable length	25 m

Mechanical data

Environmental class	Meets EN 1434 Class A and C	Weight	0.4 kg excluding sensors and flow sensor
Ambient temperature	5...55°C non condensing, closed location (indoor installation)	Connection cables	ø3.5...6 mm
Protection class	IP54	Supply cable	ø5...10 mm
Storage temperature	-20...60°C (drained flow meter)		

Materials

Top cover	PC	Print box	ABS
Base unit	PP with TPE gaskets (thermoplastic elastomer)	Wall bracket	PC + 30% glass

Order specifications

MULTICAL® 601		Type 67-	<input type="checkbox"/>	<input type="checkbox"/>	<input type="checkbox"/>	<input type="checkbox"/>	<input type="checkbox"/>	<input type="checkbox"/>	<input type="checkbox"/>	<input type="checkbox"/>	<input type="checkbox"/>
Sensor connection											
Pt100	2-wire (T1-T2)	A									
Pt500	4-wire (T1-T2)	B									
Pt500	2-wire (T1-T2-T3)	C									
Pt500	4-wire (T1-T2) w/24 V pulse inputs	D									
Top module											
No module		0									
RTC (Real Time Clock)		1									
RTC + ΔEnergy calculation + hourly data logger		2									
RTC + PQ or Δt-limiter + hourly data logger		3									
RTC + data output + hourly data logger		5									
RTC + 66-C compatibility + pulse outputs (CE and CV)		6									
RTC + M-Bus		7									
RTC + 2 pulse outputs for energy + volume + hourly data logger		8									
RTC + ΔVolume + hourly data logger		9									
Base module											
No module		00									
Data + pulse inputs		10									
M-Bus + pulse inputs		20									
RadioRouter + pulse inputs		21									
0/4...20 mA outputs		23									
LonWorks, FTT-10A + pulse inputs		24									
Radio + pulse inputs (internal antenna)		25									
Radio + pulse inputs (external antenna connection)		26									
M-Bus + pulse inputs (MULTICAL® III compatible)		<i>Require top module</i>	04								
M-Bus + pulse inputs (MULTICAL® 66-C compatible)		<i>67-x6</i>	08								
Supply											
No supply		0									
Battery, D-cell		2									
230 VAC supply module w/transformer		7									
24 VAC supply module w/transformer		8									
Pt500 sensor set											
No sensor set		0									
Pocket sensor set w/1.5 m cable		A									
Pocket sensor set w/3.0 m cable		B									
Pocket sensor set w/5 m cable		C									
Pocket sensor set w/10 m cable		D									
Short direct sensor set w/1.5 m cable		F									
Short direct sensor set w/3.0 m cable		G									
3 pocket sensors in sets w/10 m cable		P									
Flow sensor/pick-up unit											
Supplied w/1 ULTRAFLOW®		(Please specify type)	1								
Supplied w/2 (identical) ULTRAFLOW®		(Please specify type)	2								
Supplied with Kamstrup pick-up unit set			F								
Prepared for 1 ULTRAFLOW®		(Please specify type)	7								
Prepared for 2 (identical) ULTRAFLOW®		(Please specify type)	8								
Prepared for meters w/electronic pulse output			K								
Prepared for meters w/reed switch output (both V1 and V2)			L								
Prepared for meters w/24 V active pulses			M								
Meter type											
Heat meter, MID marked			2								
Heat meter, closed systems			4								
Cooling meter			5								
Heat/cooling meter			6								
Volume meter, hot water			7								
Volume meter, cooling water			8								
Energy meter, open systems			9								
Country code (language on label etc.)										XX	

When placing orders please state ULTRAFLOW® type numbers separately.

Accessories

Description	Type No.
D-cell battery	66-00-200-100
Pulse transmitter/divider for 67-A and 67-C	66-99-608/-609/-610
4-wire connection PCB with pulse inputs for 24 V active pulses (for 67-D)	66-99-614
Data cable w/USB plug	66-99-098
Infrared optical reading head w/USB plug	66-99-099
Infrared optical reading head w/D-sub 9F	66-99-102
Data cable RS 232, D-sub 9F	66-99-106
Verification unit (used with METERTOOL)	66-99-397/-398/-399
USB to serial converter	59-20-147
Temperature sensor set with connecting head (2/4 wired)	65-56-4x-xxx
METER TOOL for MULTICAL® 601	66-99-704
METER TOOL LogView for MULTICAL® 601	66-99-705

Please contact Kamstrup A/S for questions concerning further accessories.

Tolerance band

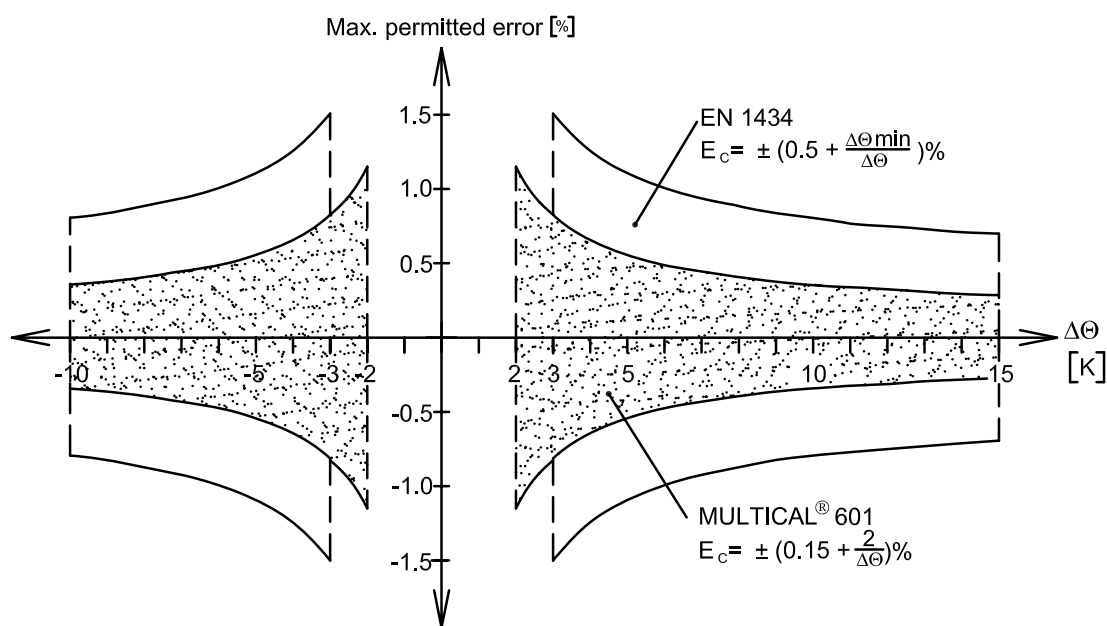

The above diagram shows the tolerance band of MULTICAL® 601 compared to the tolerance requirements of EN 1434.

Dimentional sketches

MULTICAL® 601 mounted on ULTRAFLOW®

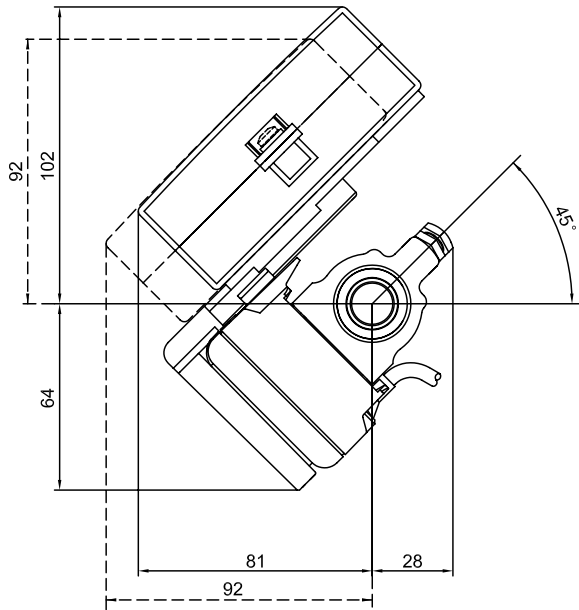

Front dimensions of MULTICAL® 601

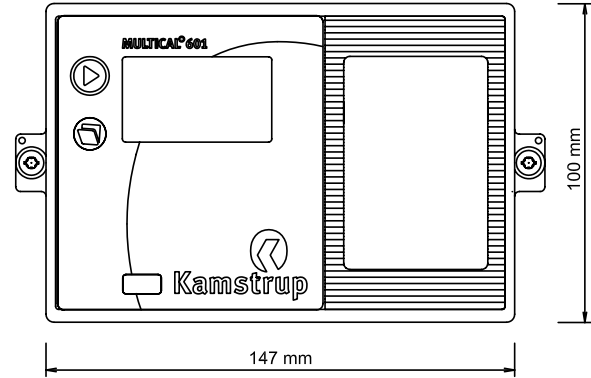

Wall-mounted MULTICAL® 601 seen from the side

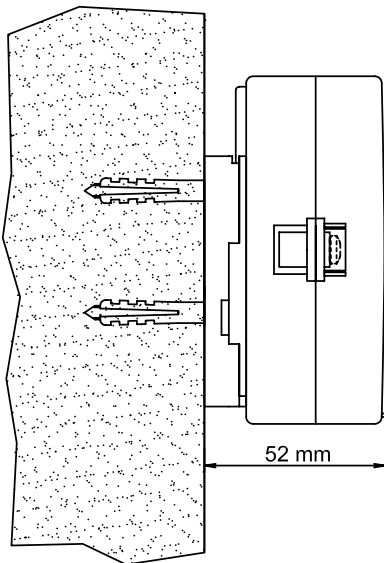

Panel-mounted MULTICAL® 601 seen from the side

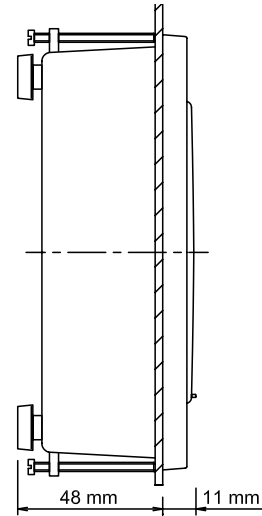

Panel-mounted MULTICAL® 601 seen from the front

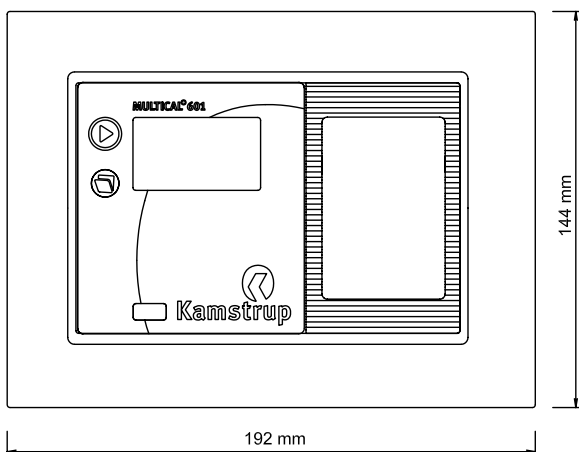

5810-490 GB / 09.2007 / E1